

MORAY COUNCIL LOCAL REVIEW BODY

Review Decision Notice

Decision by Moray Local Review Body (the MLRB)

- Request for Review reference : Case 031
- Site address: 72 Pinewood Road, Mosstodloch
- Application for review by Mr Iain MacLeod against the decision by an Appointed Officer of Moray Council.
- Application10/01928/APP : Retrospective change of use of waste ground to garden ground.
- Unaccompanied site inspection carried out by the MLRB on Monday 25 July 2011.
- Date of Decision Notice: August 2011

Decision

The MLRB agreed to uphold the request for review and grant retrospective planning permission for the change of use of waste ground to garden ground.

1.0 Preliminary

- 1.1 This Notice constitutes the formal decision notice of the Moray Local Review Body (MLRB) as required by the Town and Country Planning (Schemes of Delegation and Local Review Procedure) (Scotland) Regulations 2008.
- 1.2 The above application for full planning permission was considered by the MLRB at meetings on 26 May and 28 July 2011. The Review Body was attended at both meetings by Councillors B Jarvis (Chairman), L Creswell & G Leadbitter.

2.0 Proposal

- 2.1 This is an application for retrospective planning permission for the chance of use from waste ground to garden ground at 72 Pinewood Road, Mosstodloch.

MLRB Consideration of request for review

- 3.1 At the meeting of the MLRB on 26 May 2011 there was submitted a Summary of Information report setting out the reasons for refusal together with a copy of the Report of Handling, a copy of the Notice of Review and a copy of the Grounds for Review and supporting documents
- 3.2 Following consideration of the case papers the MLRB agreed that it did not have sufficient information in order to proceed to determine the request for review and agreed that an unaccompanied site inspection be undertaken, the purpose of which being to view the site in the context of Policies E4, ENV6, ENV10 and IMPI of the Moray Local Plan 2008. The MLRB also requested that the Planning Adviser attend the unaccompanied site inspection.
- 3.3 Councillor Leadbitter referred to the reference in the Report of Handling to seven properties having extended their garden ground/curtilage into the amenity strip and requested that clarification be sought from the Appointed Officer in regard to the locations of these properties and the current position regarding enforcement proceedings which may be ongoing. He also referred to a reference in the appellant's grounds for review in regard to 'advice received at the time was to fence off the purchased piece of ground' and requested that the appellant be requested to clarify from whom this advice had been obtained, for instance the Appellant's own legal adviser, or an officer of the Council. The MLRB agreed that the information requested by Councillor Leadbitter be obtained through the 'Written Submission' procedures set out in Regulation 15 of the Town & Country Planning (Schemes of Delegation and Local Review Procedure) (Scotland) Regulations 2008 and the responses thereto submitted to the next meeting of the MLRB following expiry of the written submission procedure timescales and the unaccompanied site inspection.
- 3.4 At the meeting of the MLRB on 28 July 2011 there was submitted a 'Summary of Information' report detailing the outcome of the MLRB's previous consideration of the request for review and advising the unaccompanied site inspection was carried out on Monday 25 July 2011. There were also appended to the report as Appendices 1& 2 respectively a response from the Appointed Officer to the written submission request and one from the appellant.
- 3.5 In regard to the unaccompanied site inspection the Planning Adviser advised the meeting that on arrival at the site he reminded members of the MLRB of the reasons for refusal and the appellant's grounds for review. Members then viewed the site under review and accessed the track to the rear of the property and proceeded along the track to the west to see other examples where enclosure for additional garden ground had taken place.
- 3.6 The MLRB agreed that it had sufficient information and proceeded to determine the request for review.
- 3.7 Councillor Jarvis sought clarification in regard to the reasoning for establishing a 'buffer zone' between the housing development and agricultural land. The Planning Adviser advised the meeting that the reason was in order to provide separation between the agricultural land to the north and the settlement of Mosstodloch and provides a distinction between the two and the amenity value of it.

- 3.8 Thereafter Councillor Jarvis expressed the view, having considered all aspects of the case and having the opportunity to visit the site, that rather than being detrimental to the concept of the area being an informal recreational open space or having a significant and detrimental impact on the amenity of the area the enclosed additional garden ground was a significant improvement to the area and for these reasons the request for review should be upheld and retrospective consent granted. Councillor Creswell supported Councillor Jarvis's views and added that, in her opinion, the enclosed additional garden ground enhanced the area rather than having a detrimental impact as implied in the grounds for refusal.
- 3.9 Councillor Leadbitter intimated that there were no objections to the proposal from the community and expressed the view that given several parcels of amenity land had been acquired by householders for additional garden ground it would be very difficult to develop the amenity zone in a planned manner. He also expressed the view that it was clear from the site inspection that the amenity on the north side of the core path is much more sympathetic than the amenity to the south side of the core path bordering the houses, which can be described as scrub land. He was also of the view that the core path is clearly defined and the enclosed additional areas of garden ground do not encroach onto the path. Councillor Leadbitter also referred to Policies E4, ENV6 & ENV10 and was of the opinion that whilst the enclosure of the additional garden ground does not outweigh the value of the open space its conversion into garden ground in this case provides a greater degree of amenity and enhances the area. He was also of the view that the provision of additional garden ground was, in effect, an improvement to the landscaped setting as opposed to what previously existed. It was in his opinion the areas to the north and west of the core path that require to be protected. For these reasons Councillor Leadbitter was also of the view that the request for review should be upheld and retrospective consent granted for the change of use to garden ground.
- 3.10 Thereafter the MLRB agreed that the views expressed by the MLRB members were a material consideration of such weight to justify departing from policy and agreed that the request for review and be granted and retrospective planning consent be granted as an acceptable departure from the Moray Local Plan 2008, subject to standard conditions.

.....

Rhona Gunn
Legal Adviser to the MLRB

CONDITIONS

1. The development to which this permission relates must be begun not later than the expiration of 3 years beginning with the date on which this permission is granted.
2. Unless otherwise agreed with the Council, as Planning Authority, the development hereby approved shall be carried out strictly in accordance with the approved plans and conditions.

REASONS

1. The time limit condition is imposed in order to comply with the requirements of Section 59 of the Town and Country Planning (Scotland) Act 1997 as amended by the Planning etc. (Scotland) Act 2006.
2. In order to ensure that there are no unauthorised departures from the approved plans which could adversely affect the development or character and amenity of the surrounding properties and area

TOWN AND COUNTRY PLANNING (SCOTLAND) ACT 1997

Notification to be sent to applicant on determination by the planning authority of an application following a review conducted under section 43A(8)

Notice Under Regulation 21 of the Town and Country Planning (Schemes of Delegation and Local Review Procedure) (Scotland) Regulations 2008.

- 1 If the applicant is aggrieved by the decision of the planning authority to refuse permission or approval required by a condition in respect of the proposed development, or to grant permission or approval subject to conditions, the applicant may question the validity of that decision by making an application to the Court of Session. An application to the Court of Session must be made within 6 weeks of the date of the decision.

- 2 If permission to develop land is refused or granted subject to conditions and the owner of the land claims that the land has become incapable of reasonably beneficial use in its existing state and cannot be rendered capable of reasonably beneficial use by the carrying out of any development which has been or would be permitted, the owner of the land may serve on the planning authority a purchase notice requiring the purchase of the owner of the land's interest in the land in accordance with Part V of the Town and Country Planning (Scotland) Act 1997.

1. Do not scale drawing. All dimensions and levels to be verified on site by Contractor.
2. Any discrepancies to be reported to the designer.

Revisions:



CP Plans
 2 Balvenie Park
 Elgin
 IV30 8AJ

Tel: 07467 231872
 cpplanselgin@gmail.com

Job Title

New rear boundary fence
 at 10 Linksfield Road
 Mosstodloch
 IV32 7LB

Drawing Title

Fence & gate plan

Drawing Number

PL-01

Scale	Date	Rev
1:200	Oct 22	

Drawing by CP

1. Do not scale drawing. All dimensions and levels to be verified on site by Contractor.
2. Any discrepancies to be reported to the designer.

Revisions:

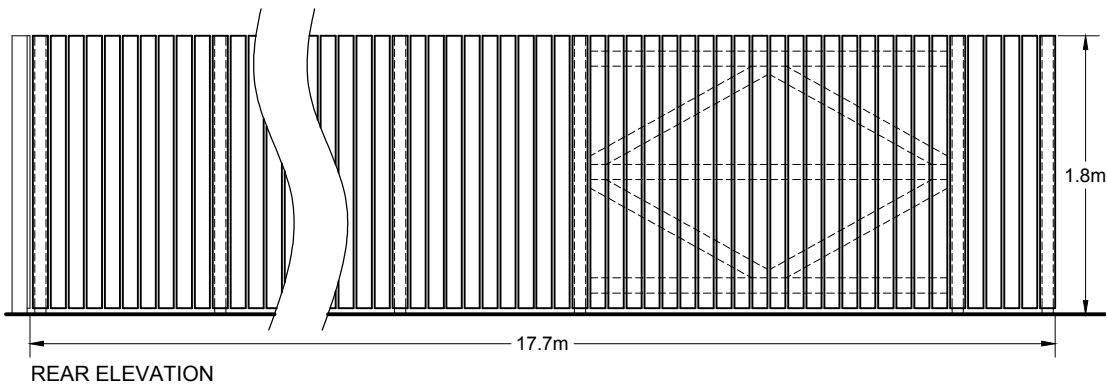
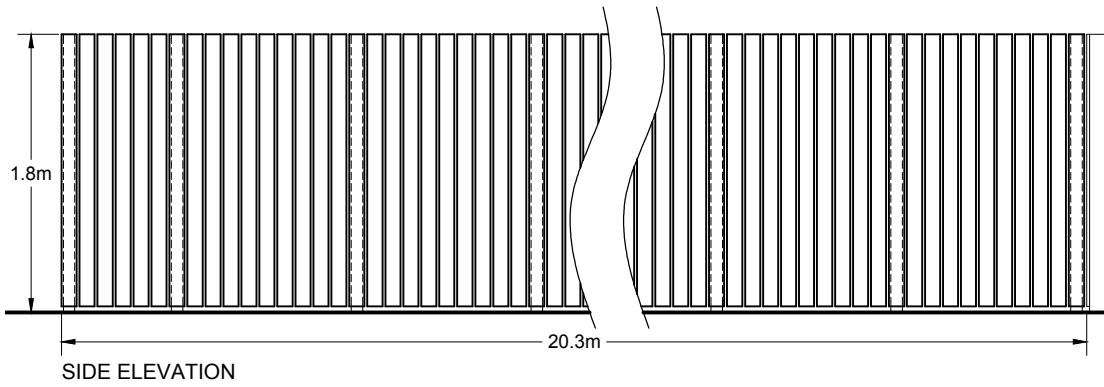

CP Plans
2 Balvenie Park
Elgin
IV30 8AJ

Tel: 07467 231872
cpplanselgin@gmail.com

Job Title

New rear boundary fence
at 10 Linksfield Road
Mosstodloch
IV32 7LB

Drawing Title

Fence elevations

Drawing Number

PL-02

Scale	Date	Rev
1:50	Oct 22	

Drawing by CP

10 Linksfield Road, Mosstodloch, Fochabers, IV32 7LB

