



The Moray Council Council Office High Street Elgin IV30 1BX Tel: 0300 1234561 Email: development.control@moray.gov.uk

Applications cannot be validated until all the necessary documentation has been submitted and the required fee has been paid.

Thank you for completing this application form:

ONLINE REFERENCE 100477701-001

The online reference is the unique reference for your online form only. The Planning Authority will allocate an Application Number when your form is validated. Please quote this reference if you need to contact the planning Authority about this application.

Type of Application

What is this application for? Please select one of the following: *

- Application for planning permission (including changes of use and surface mineral working).
- Application for planning permission in principle.
- Further application, (including renewal of planning permission, modification, variation or removal of a planning condition etc)
- Application for Approval of Matters specified in conditions.

Description of Proposal

Please describe the proposal including any change of use: * (Max 500 characters)

Proposed Dwellinghouse

Is this a temporary permission? * Yes No

If a change of use is to be included in the proposal has it already taken place?
(Answer 'No' if there is no change of use.) * Yes No

Has the work already been started and/or completed? *

No Yes – Started Yes - Completed

Applicant or Agent Details

Are you an applicant or an agent? * (An agent is an architect, consultant or someone else acting on behalf of the applicant in connection with this application)

Applicant Agent

Agent Details

Please enter Agent details

| | | | |
|-----------------------|-------------------------------|--|---------------------|
| Company/Organisation: | John Wink Design | | |
| Ref. Number: | | You must enter a Building Name or Number, or both: * | |
| First Name: * | John | Building Name: | Midtown of Foudland |
| Last Name: * | Wink | Building Number: | |
| Telephone Number: * | 01464841113 | Address 1 (Street): * | Glens of Foudland |
| Extension Number: | | Address 2: | |
| Mobile Number: | | Town/City: * | Huntly |
| Fax Number: | | Country: * | Scotland |
| | | Postcode: * | AB54 6AR |
| Email Address: * | planning@johnwinkdesign.co.uk | | |

Is the applicant an individual or an organisation/corporate entity? *

Individual Organisation/Corporate entity

Applicant Details

Please enter Applicant details

| | | | |
|----------------------|-------------------------------|--|----------------------|
| Title: | Other | You must enter a Building Name or Number, or both: * | |
| Other Title: | Mr & Mrs | Building Name: | c/o John Wink Design |
| First Name: * | S | Building Number: | |
| Last Name: * | Hancox | Address 1 (Street): * | Midtown of Foudland |
| Company/Organisation | | Address 2: | Glens of Foudland |
| Telephone Number: * | | Town/City: * | Huntly |
| Extension Number: | | Country: * | Aberdeenshire |
| Mobile Number: | | Postcode: * | AB54 6AR |
| Fax Number: | | | |
| Email Address: * | planning@johnwinkdesign.co.uk | | |

Site Address Details

Planning Authority:

Moray Council

Full postal address of the site (including postcode where available):

Address 1:

Address 2:

Address 3:

Address 4:

Address 5:

Town/City/Settlement:

Post Code:

Please identify/describe the location of the site or sites

Land at Stratton Wood, Fochabers

Northing

858191

Easting

330055

Pre-Application Discussion

Have you discussed your proposal with the planning authority? *

Yes No

Site Area

Please state the site area:

5640.00

Please state the measurement type used:

Hectares (ha) Square Metres (sq.m)

Existing Use

Please describe the current or most recent use: * (Max 500 characters)

Woodland

Access and Parking

Are you proposing a new altered vehicle access to or from a public road? *

Yes No

If Yes please describe and show on your drawings the position of any existing. Altered or new access points, highlighting the changes you propose to make. You should also show existing footpaths and note if there will be any impact on these.

Are you proposing any change to public paths, public rights of way or affecting any public right of access? * Yes No

If Yes please show on your drawings the position of any affected areas highlighting the changes you propose to make, including arrangements for continuing or alternative public access.

Water Supply and Drainage Arrangements

Will your proposal require new or altered water supply or drainage arrangements? * Yes No

Are you proposing to connect to the public drainage network (eg. to an existing sewer)? *

- Yes – connecting to public drainage network
 No – proposing to make private drainage arrangements
 Not Applicable – only arrangements for water supply required

As you have indicated that you are proposing to make private drainage arrangements, please provide further details.

What private arrangements are you proposing? *

- New/Altered septic tank.
 Treatment/Additional treatment (relates to package sewage treatment plants, or passive sewage treatment such as a reed bed).
 Other private drainage arrangement (such as chemical toilets or composting toilets).

What private arrangements are you proposing for the New/Altered septic tank? *

- Discharge to land via soakaway.
 Discharge to watercourse(s) (including partial soakaway).
 Discharge to coastal waters.

Please explain your private drainage arrangements briefly here and show more details on your plans and supporting information: *

Refer to drainage impact assessment provided by MacLeod & Jordan

Do your proposals make provision for sustainable drainage of surface water?? * Yes No
(e.g. SUDS arrangements) *

Note:-

Please include details of SUDS arrangements on your plans

Selecting 'No' to the above question means that you could be in breach of Environmental legislation.

Are you proposing to connect to the public water supply network? *

- Yes
 No, using a private water supply
 No connection required

If No, using a private water supply, please show on plans the supply and all works needed to provide it (on or off site).

Assessment of Flood Risk

Is the site within an area of known risk of flooding? *

Yes No Don't Know

If the site is within an area of known risk of flooding you may need to submit a Flood Risk Assessment before your application can be determined. You may wish to contact your Planning Authority or SEPA for advice on what information may be required.

Do you think your proposal may increase the flood risk elsewhere? *

Yes No Don't Know

Trees

Are there any trees on or adjacent to the application site? *

Yes No

If Yes, please mark on your drawings any trees, known protected trees and their canopy spread close to the proposal site and indicate if any are to be cut back or felled.

All Types of Non Housing Development – Proposed New Floorspace

Does your proposal alter or create non-residential floorspace? *

Yes No

Schedule 3 Development

Does the proposal involve a form of development listed in Schedule 3 of the Town and Country Planning (Development Management Procedure (Scotland) Regulations 2013) *

Yes No Don't Know

If yes, your proposal will additionally have to be advertised in a newspaper circulating in the area of the development. Your planning authority will do this on your behalf but will charge you a fee. Please check the planning authority's website for advice on the additional fee and add this to your planning fee.

If you are unsure whether your proposal involves a form of development listed in Schedule 3, please check the Help Text and Guidance notes before contacting your planning authority.

Planning Service Employee/Elected Member Interest

Is the applicant, or the applicant's spouse/partner, either a member of staff within the planning service or an elected member of the planning authority? *

Yes No

Certificates and Notices

CERTIFICATE AND NOTICE UNDER REGULATION 15 – TOWN AND COUNTRY PLANNING (DEVELOPMENT MANAGEMENT PROCEDURE) (SCOTLAND) REGULATION 2013

One Certificate must be completed and submitted along with the application form. This is most usually Certificate A, Form 1, Certificate B, Certificate C or Certificate E.

Are you/the applicant the sole owner of ALL the land? *

Yes No

Is any of the land part of an agricultural holding? *

Yes No

Certificate Required

The following Land Ownership Certificate is required to complete this section of the proposal:

Certificate A

Land Ownership Certificate

Certificate and Notice under Regulation 15 of the Town and Country Planning (Development Management Procedure) (Scotland) Regulations 2013

Certificate A

I hereby certify that –

(1) - No person other than myself/the applicant was an owner (Any person who, in respect of any part of the land, is the owner or is the lessee under a lease thereof of which not less than 7 years remain unexpired.) of any part of the land to which the application relates at the beginning of the period of 21 days ending with the date of the accompanying application.

(2) - None of the land to which the application relates constitutes or forms part of an agricultural holding

Signed: John Wink

On behalf of: Mr & Mrs S Hancox

Date: 24/09/2021

Please tick here to certify this Certificate. *

Checklist – Application for Planning Permission

Town and Country Planning (Scotland) Act 1997

The Town and Country Planning (Development Management Procedure) (Scotland) Regulations 2013

Please take a few moments to complete the following checklist in order to ensure that you have provided all the necessary information in support of your application. Failure to submit sufficient information with your application may result in your application being deemed invalid. The planning authority will not start processing your application until it is valid.

a) If this is a further application where there is a variation of conditions attached to a previous consent, have you provided a statement to that effect? *

Yes No Not applicable to this application

b) If this is an application for planning permission or planning permission in principle where there is a crown interest in the land, have you provided a statement to that effect? *

Yes No Not applicable to this application

c) If this is an application for planning permission, planning permission in principle or a further application and the application is for development belonging to the categories of national or major development (other than one under Section 42 of the planning Act), have you provided a Pre-Application Consultation Report? *

Yes No Not applicable to this application

Town and Country Planning (Scotland) Act 1997

The Town and Country Planning (Development Management Procedure) (Scotland) Regulations 2013

d) If this is an application for planning permission and the application relates to development belonging to the categories of national or major developments and you do not benefit from exemption under Regulation 13 of The Town and Country Planning (Development Management Procedure) (Scotland) Regulations 2013, have you provided a Design and Access Statement? *

Yes No Not applicable to this application

e) If this is an application for planning permission and relates to development belonging to the category of local developments (subject to regulation 13. (2) and (3) of the Development Management Procedure (Scotland) Regulations 2013) have you provided a Design Statement? *

Yes No Not applicable to this application

f) If your application relates to installation of an antenna to be employed in an electronic communication network, have you provided an ICNIRP Declaration? *

Yes No Not applicable to this application

g) If this is an application for planning permission, planning permission in principle, an application for approval of matters specified in conditions or an application for mineral development, have you provided any other plans or drawings as necessary:

- Site Layout Plan or Block plan.
- Elevations.
- Floor plans.
- Cross sections.
- Roof plan.
- Master Plan/Framework Plan.
- Landscape plan.
- Photographs and/or photomontages.
- Other.

If Other, please specify: * (Max 500 characters)

Provide copies of the following documents if applicable:

- | | | |
|--|---|---|
| A copy of an Environmental Statement. * | <input type="checkbox"/> Yes | <input checked="" type="checkbox"/> N/A |
| A Design Statement or Design and Access Statement. * | <input type="checkbox"/> Yes | <input checked="" type="checkbox"/> N/A |
| A Flood Risk Assessment. * | <input type="checkbox"/> Yes | <input checked="" type="checkbox"/> N/A |
| A Drainage Impact Assessment (including proposals for Sustainable Drainage Systems). * | <input checked="" type="checkbox"/> Yes | <input type="checkbox"/> N/A |
| Drainage/SUDS layout. * | <input type="checkbox"/> Yes | <input checked="" type="checkbox"/> N/A |
| A Transport Assessment or Travel Plan | <input type="checkbox"/> Yes | <input checked="" type="checkbox"/> N/A |
| Contaminated Land Assessment. * | <input type="checkbox"/> Yes | <input checked="" type="checkbox"/> N/A |
| Habitat Survey. * | <input type="checkbox"/> Yes | <input checked="" type="checkbox"/> N/A |
| A Processing Agreement. * | <input type="checkbox"/> Yes | <input checked="" type="checkbox"/> N/A |

Other Statements (please specify). (Max 500 characters)

Declare – For Application to Planning Authority

I, the applicant/agent certify that this is an application to the planning authority as described in this form. The accompanying Plans/drawings and additional information are provided as a part of this application.

Declaration Name: Mr John Wink

Declaration Date: 18/10/2021

Payment Details

Cheque: 0, 0

Created: 18/10/2021 11:28

| Rev. | Details: | Date: | By: |
|------|----------|-------|-----|
| | | | |
| | | | |
| | | | |

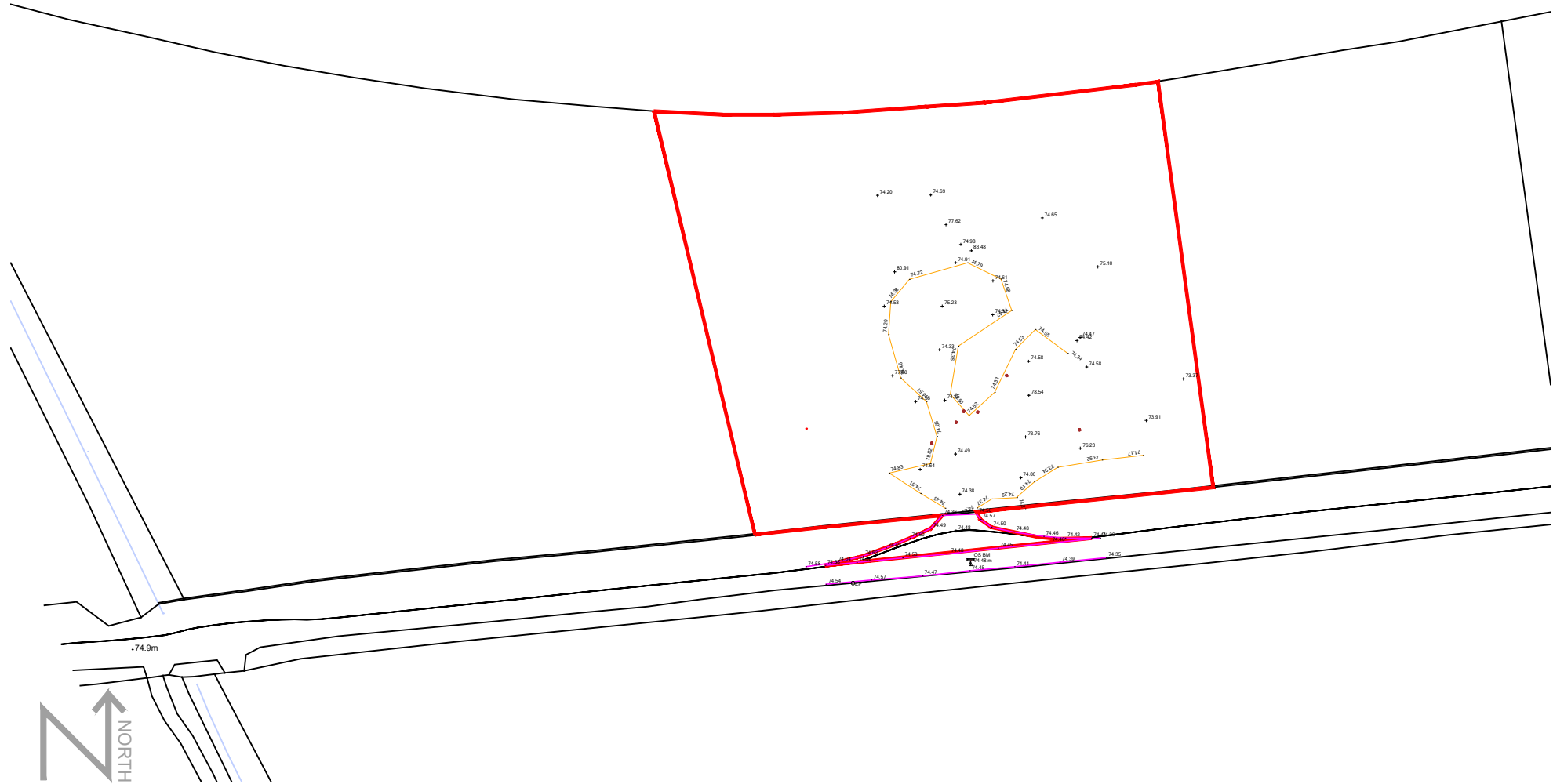

Site Plan
Scale 1:1,000

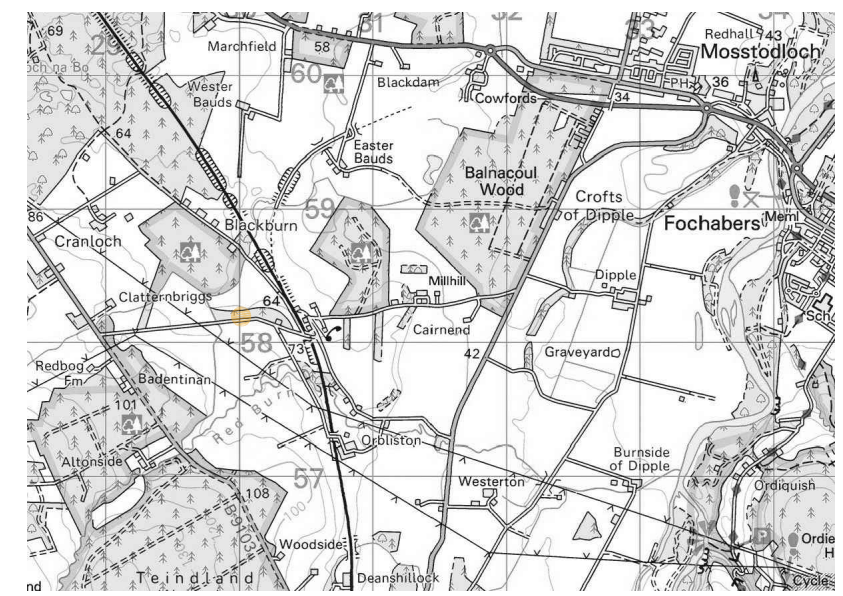



OS map
Scale 1:25,000

Site Area

- 5,640m²
- 1.39 acres
- 0.564 hectares



Existing Photographs

| | | |
|--|-----------|--|
| Project | |  |
| Development at, | | |
| Land at Stratton Wood, Fochabers, IV32 7LN | | |
| For Mr & Mrs S Hancox | |   |
| Drawing | | |
| Existing Site plan & photographs | | <p>t-01464 841113 e-office@johnwinkdesign.co.uk Midtown of Foudland Glens of Foudland Huntly Aberdeenshire AB54 6AR</p> <p>Note Dimensions must not be scaled from this drawing. If in any doubt - ask! All dimensions to be checked prior to work commencing or prior to any components being manufactured. Any discrepancy to be reported. All work and material to comply fully with all current British Standards Codes of Practice, building regulations, IEE regulations and all HSE acts.</p> <p>This drawing is copyright of John Wink Design. ©</p> |
| Scale | Date | |
| As noted @ A3 | July 2021 | |
| Revision | Drg No | |
| - | 2518-001 | |

| Rev: | Details: | Date: | By: |
|------|--|--------|-----|
| A | Plan updated in line with Astel Associates survey & report | Feb 22 | JK |
| B | Replacement planting & maintenance scheme added | Feb 22 | KU |



Landscape Notes

New Trees
 9no. trees to be felled for development to be replaced with 18no. trees of native species.

Trees to be Planted
 New trees (normal) to be staked and guarded with tubes and tied at the base and positioned as shown on layout drawing.
 New trees (heavy standard) to be staked and tied at the base and positioned as shown on layout drawing.
 A barrier system, such as terrac panels, must be placed along the limit of the root protection area to protect the remaining trees on site.
 Tree works should be carried out between November and March (ensuring nesting birds are not present).
 A replanting scheme consisting of small to medium sized native trees appropriate to a garden setting such as rowan, birch and cherry should be planted on a two to one basis for all trees removed and there are several suitable sites on the plot that will provide nature screening between dwellings as indicated.

Maintenance

1. Weed killing, annually for first 3 years apply an approved herbicide to a
2. 1.0m diam. Area surrounding every new tree annually.
3. Until removed ensure that all tubes are securely attached to stakes
4. All plants not established in first year to be replaced the following year.
5. New saplings, in 5 years time, remove any remaining stakes and tubes.
6. Remove any dead trees following first planting season and dig over area ready for replacement tree
7. Plant any replacement trees to original specification and type, following the first growing season after planting. Check trees for any sign of disease and treat as appropriate.
8. Weeding as required.
9. Water all new trees (particularly in first season following planting) as required during dry periods.

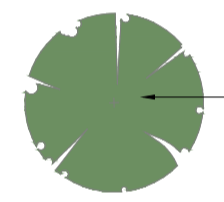
 Replacement trees

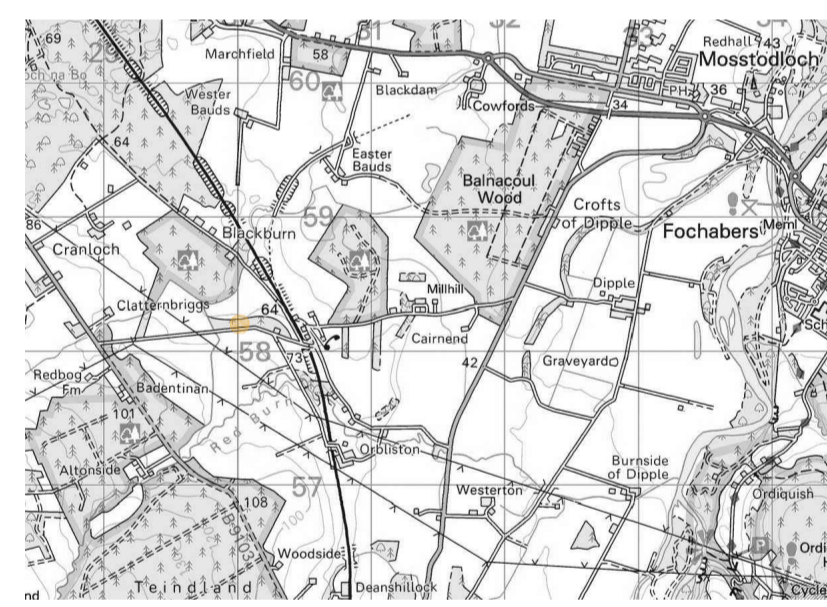

OS map
 Scale nits

Site Area

- 5,640m²
- 1.39 acres
- 0.564 hectares

| | |
|--|-------------|
| Project | |
| Proposed Dwellinghouse at, | |
| Land at Stratton Wood, Fochabers, IV32 7LN | |
| For Mr & Mrs S Hancox | |
| Drawing | |
| Proposed Site Plan | |
| Scale | Date |
| As noted @ A1 | August 2021 |
| Revision | Dwg No |
| B | 2518-020 |
| 1-01464 841113 e-office@johnwinkdesign.co.uk Midtown of Foudland Glens of Foudland Huntly Aberdeenshire AB54 6AR | |
| Note Dimensions must not be scaled from this drawing. If in any doubt - ask! All dimensions to be checked prior to work commencing or prior to any components being manufactured. Any discrepancy to be reported. All work and material to comply fully with all current British Standards Codes of Practice, building regulations, IEE regulations and all HSE acts. | |
| This drawing is copyright of John Wink Design. © | |

JOHN WINK DESIGN

For Mr & Mrs S Hancox

CIAT
 Registered Practice

CHARTERED PRACTICE

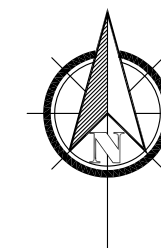

- Trees to retain
- Fell for health and safety
- Fell for development
- Root protection area (RPA)
- RPA trees to be felled
- Tree canopy
- Tree protection fencing
- Boundary

Note: The original of this drawing was produced in colour – a monochrome copy should not be relied upon

Proposed New House at Stratton Woods, Fochabers
Tree Protection & Management

| | | | |
|-------------|-------------------|-------------|-------|
| Client: | Samantha Hancox | | |
| Drawing No: | SWF-2202-TP | | |
| Issue Date: | 8th February 2022 | | |
| Drawn by: | AM | Checked by: | EP/NA |
| Revision: | | Rev Date: | |
| Scale: | 1:300 A A3 | | |

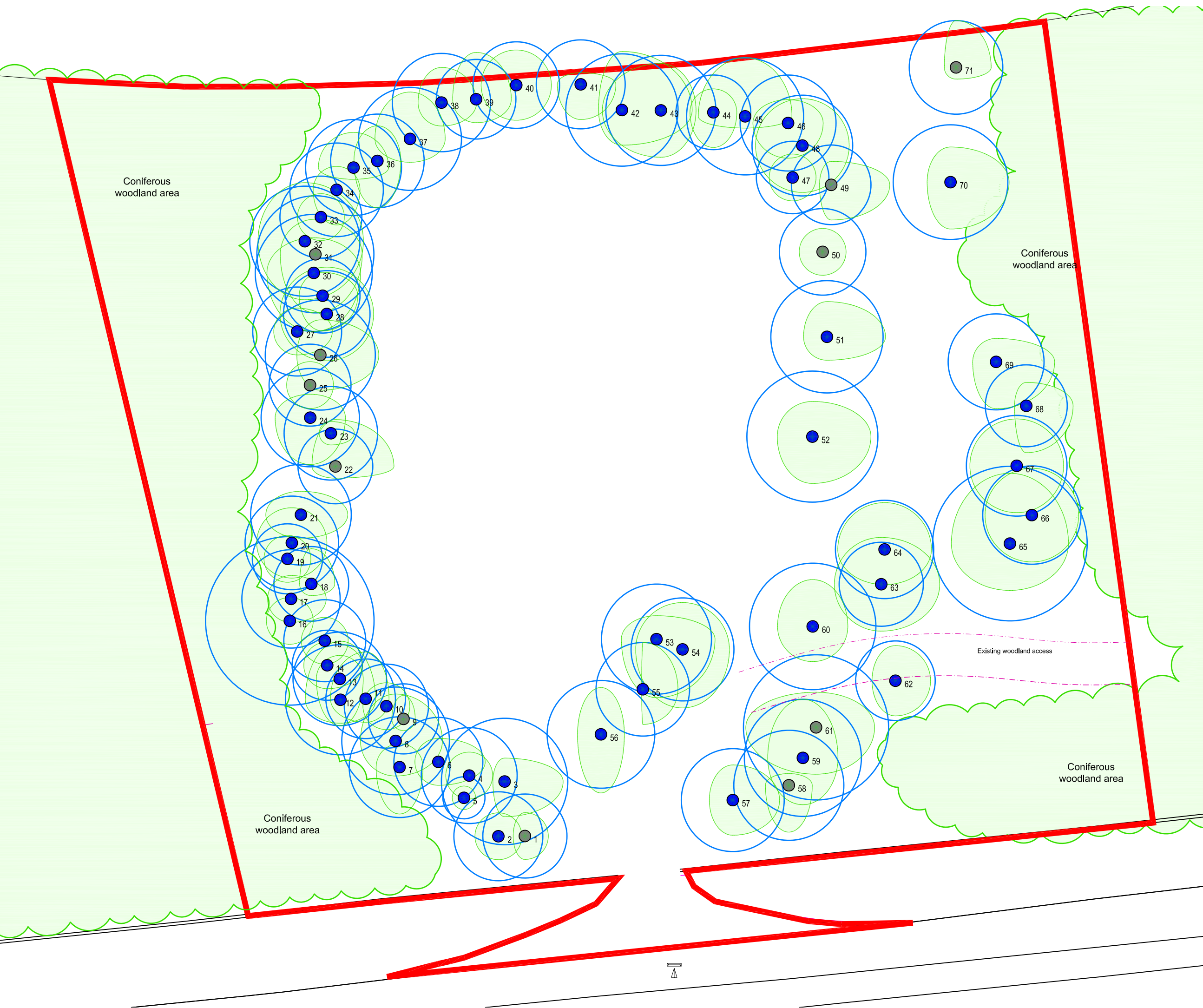
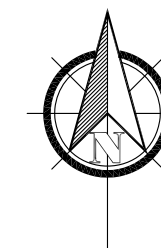

- Category A Trees
- Category B Trees
- Category C Trees
- Category U Trees

○ Root protection area

○ Tree canopy

Note: The original of this drawing was produced in colour – a monochrome copy should not be relied upon

Proposed New House at Stratton Woods, Fochabers
Arboricultural Assessment

| | | | |
|-------------|-------------------|-------------|-------|
| Client: | Samantha Hancox | | |
| Drawing No: | SWF-2202-AA | | |
| Issue Date: | 8th February 2022 | | |
| Drawn by: | AM | Checked by: | EP/NA |
| Revision: | | Rev Date: | |
| Scale: | 1:300 A A3 | | |

 **astell associates**
arboricultural, environmental and landscape consultants
10 Polston Road, Maryculter, Aberdeen, AB12 5GY
tel: 01224 734372 email: info@astellassociates.co.uk

**MACLEOD
JORDAN**



**16371 – PLOT 3, STRATTON WOOD, FOCHABERS,
MORAY, IV32 7LN**

DRAINAGE ASSESSMENT

16371-DIA-001



MacLeod+Jordan
Civil & Structural Consulting Engineers
16 Albert Street
Aberdeen
AB25 1XQ
T – 01224 646555
E – info@macleodjordan.co.uk

| Revision | Date | Notes | Prepared By | Approved By |
|----------|------------|-------------|-------------|-------------|
| - | 07/10/2021 | First Issue | NM | RM |
| | | | | |
| | | | | |

CONTENTS

| | | |
|------------|--|----------|
| 1.0 | INTRODUCTION | 1 |
| 1.1 | Purpose and Scope | 1 |
| 1.2 | National and Regional Guidance | 1 |
| 2.0 | DEVELOPMENT SITE | 2 |
| 2.1 | Existing Site Conditions | 2 |
| 2.1.1 | Topography and boundaries | 2 |
| 2.1.2 | Hydrology | 2 |
| 2.1.3 | Geology | 2 |
| 2.1.4 | Groundwater | 2 |
| 2.1.5 | Flood risk | 2 |
| 2.2 | Site Investigation | 3 |
| 2.3 | Existing Drainage | 3 |
| 2.4 | Existing Surface Water Run-off | 3 |
| 2.5 | Proposed Development | 3 |
| 3.0 | PROPOSED DRAINAGE STRATEGY | 3 |
| 3.1 | Selection of surface water drainage strategy | 3 |
| 3.2 | Treatment of runoff from roof area | 4 |
| 3.3 | Treatment of runoff from driveway and parking area | 4 |
| 3.4 | Surface Water Soakaway Design | 5 |
| 3.5 | Foul Water Treatment Design | 5 |
| 3.6 | Maintenance | 6 |
| 4.0 | CONCLUSION | 6 |
| 5.0 | REFERENCES | 6 |

APPENDIX A

Pollution Hazard Indices

APPENDIX B

Development Drawing

APPENDIX C

Surface Water Soakaway Calculations

APPENDIX D

Foul Drainage Calculations

1.0 INTRODUCTION

1.1 Purpose and Scope

MacLeod + Jordan have been appointed to carry out a Drainage Assessment for a site at Stratton Woods, Fochabers, Moray, IV32 7LN. A new 4/5-bedroomed house with a garage is proposed.

The site is located approximately 5km west of Fochabers at approx NGR NJ 2998 5820, as shown in Figure 1.

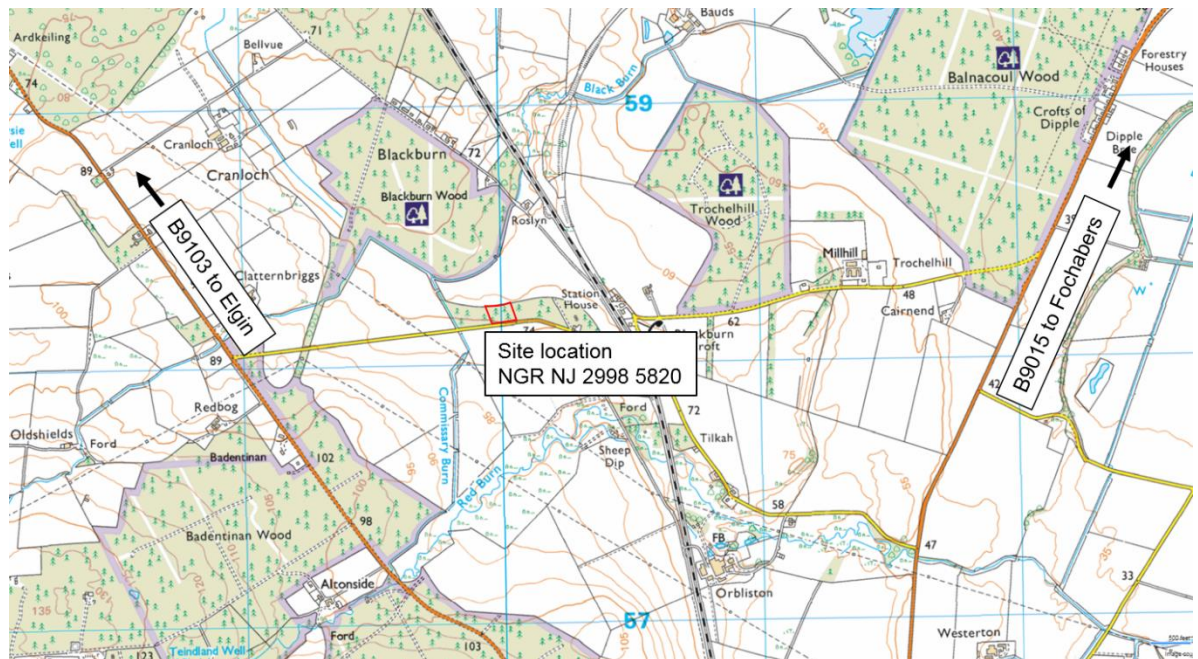

Figure 1: Site location plan

This Drainage Assessment evaluates the current proposals with regards to drainage and identifies potential flood risk from the development. It also provides an assessment of the surface water run-off from the development and provision of water quality treatment.

1.2 National and Regional Guidance

This drainage impact assessment is prepared in accordance with the guidance given in the following documents:

- Moray Council LDP Supplementary Guidance: Flood Risk and Drainage Impact Assessment for New Developments (Moray Council, 2020);
- Scottish Planning Policy: Managing Flood Risk and Drainage (Scottish Government, 2014, updated 2020);
- Water Assessment and Drainage Assessment Guide - A guidance document for developers, planners and others involved in water and drainage (SuDS Working Party, 2016);
- Planning Advice Note (PAN) 61: Planning and Sustainable Urban Drainage Systems (Scottish Executive Development Department, 2001);
- The SuDS Manual C753 (CIRIA, 2016);
- Sewers for Scotland, Fourth Edition (Scottish Water, 2018);

- The Water Environment (Controlled Activities) (Scotland) Regulations 2011, as amended;
- Scottish Government Online Planning Advice on Flood Risk 2015;
- BS EN 752:2008, Drain and Sewer systems outside buildings (BSI, 2013);
- Guideline for Pollution Prevention 4: Treatment and disposal of wastewater where there is no connection to the public foul sewer (NIEA, SEPA and NRW, 2017).
- Scottish Water: Standard advice note and process guidance: Surface Water Policy; and
- SEPA Water Use Regulatory Method (WAT-RM-04) 'Indirect Sewage Discharges to Groundwater.

2.0 DEVELOPMENT SITE

2.1 Existing Site Conditions

2.1.1 Topography and boundaries

The site is at an elevation of approximately 75m AOD at its highest point, sloping gently down to the north. It is within an area of coniferous plantation woodland, bounded to the north by arable agricultural land and to the south by an un-named minor road. The woodland extends to the east and west of Plot 3; further houses, which will be the subject of separate planning applications, are proposed within the woodland.

2.1.2 Hydrology

There are no water features on the site. The Commissary Burn, a tributary of the Red Burn, originates at Altonside, approximately 1.2km south-west of the site, and flows north-east and north to pass 140m from the western site boundary at its closest point. The Commissary Burn discharges into the Black Burn approx. 220m NW of the site boundary.

2.1.3 Geology

The British Geological Survey records the superficial deposits at the site as Pleistocene glaciofluvial ice contact deposits of stratified sand and gravel with interbedded diamicton, and solid deposits as the Spey Conglomerate Formation of Devonian age: a coarse red-bed conglomerate sequence with sporadic thin pebbly sandstone beds (BGS Geoindex).

2.1.4 Groundwater

The site is underlain by a moderately productive aquifer of the Middle Old Red Sandstone, which locally yields small amounts of groundwater (BGS Geoindex).

2.1.5 Flood risk

According to SEPA's online flood maps, the site is not at risk of fluvial or pluvial flooding.

2.2 Site Investigation

Two trial pits were excavated on the site on 3rd August 2021. The findings of these trial pits are shown in Table 1 and Table 2.

Table 1: Lithologies encountered in TP1

| Depth (m bgl) | Lithology |
|--------------------------------|-------------------|
| 0 – 0.2 | Topsoil |
| 0.2 – 1.6 | Fine/ medium sand |
| No groundwater was encountered | |

An infiltration test was carried out in TP1, yielding an infiltration rate of 7.33×10^{-5} m/s, indicating that the site is suitable for soakaway drainage.

Table 2: Lithologies encountered in TP2

| Depth (m bgl) | Lithology |
|---------------|------------------------------------|
| 0 – 0.3 | Topsoil and roots |
| 0.3 – 0.6 | Medium sands and stones and gravel |
| 0.6 – 1.4 | Fine-medium sand. |
| 1.4 m | Water struck, rising to 1.1 m bgl. |

An infiltration test was attempted in TP2, but failed due to the high water table at this point.

2.3 Existing Drainage

There is no drainage provision currently on the site.

2.4 Existing Surface Water Run-off

As the site is a greenfield site, it is assumed that water infiltrates into the soil. When rainfall exceeds the infiltration capacity of the soil, runoff will flow northwards towards the Black Burn.

2.5 Proposed Development

A 4/5-bedroom house with a garage is proposed on the site. The roof area of the house and garage combined will be approximately 236m².

3.0 PROPOSED DRAINAGE STRATEGY

3.1 Selection of surface water drainage strategy

The development is within an area of low risk of surface and river water flooding and therefore focuses, in accordance with Scottish Planning Policy (Scottish Government, 2014), on the management of surface water to ensure that the flood risk is not increased on site or elsewhere. The surface water strategy for the site will be developed in accordance with The Building (Scotland) Regulations 2004, as amended.

To minimise the risk of surface flooding, the soakaway has been designed in accordance with the guidance included within Sewers for Scotland, 4th Edition, and sized to accommodate all storm events for up to, and including, the 30-year return period, plus 35% climate change.

The Scottish Water design hierarchy for surface water (Scottish Water, 2017) has been considered as noted in Table 3.

Table 3: Selection of surface water drainage strategy using Scottish Water Drainage Hierarchy

| Scottish Water Drainage Hierarchy – Surface Water Drainage Design Options | | |
|---|-------------|---|
| Option | Suitability | Comments |
| 1) Rainwater is stored and reused, such as rainwater harvesting | N | Due to the calculated demand of the finished development, the cost of installing a suitable rain water harvesting system will be too high to be viable. |
| 2) Surface water is drained into the soil through the use of a soakaway | Y | A Site Investigation was undertaken and it was found the ground conditions are suitable for infiltration. |
| 3) Surface water is drained to a watercourse (open or piped), canal, loch or existing/proposed SuDs | N/A | |
| 4) Surface water is drained to a surface water sewer | N/A | |
| 5) Surface water is drained to a combined sewer | N/A | |

3.2 Treatment of runoff from roof area

The surface water run-off from the roof area will discharge via a series of downpipes and conveyed to a stone-filled sub-surface soakaway within the boundaries of the site.

The Simple Index approach (CIRIA, 2016) has been used to select the treatment method to be used, as shown in Table 4, below. An extract from the CIRIA document showing pollution hazard indices for different land use classifications is given in Appendix A.

Table 4: Simple Index Approach for treatment of runoff from the roof

| Indicative SUDs Mitigation Indices for Surface Water Run-off | | | |
|--|------------------------|------------|--------------|
| Total shown GREEN when Mitigation indices exceed Pollution indices | | | |
| | Total Suspended Solids | Metals | Hydrocarbons |
| Pollution Indices | | | |
| Roof run-off | 0.2 | 0.2 | 0.05 |
| Mitigation Indices | | | |
| Stone Filled Attenuation | 0.4 | 0.4 | 0.4 |
| | | | |
| Total mitigation | 0.4 | 0.4 | 0.4 |

3.3 Treatment of runoff from driveway and parking area

The driveway and parking area will be surfaced with a free-draining permeable material to allow direct infiltration.

3.4 Surface Water Soakaway Design

Runoff from the roof will discharge into a stone-filled soakaway. To minimise the risk of surface flooding, the soakaway has been designed in accordance with the guidance included within Sewers for Scotland, 4th Edition (Scottish Water, 2018), and sized to accommodate all storm events up to and including the 30-year return period, plus 35% climate change.

The soakaway has been designed with reference to a proprietary system: calculations using MicroDrainage show that the required soakaway volume is 5m long x 4m wide x 1m deep.

Site levels will be set so as to route surface water runoff around and away from buildings and major access and egress routes, to minimise damage to property and ensure that movement of emergency vehicles is not restricted.

Drawing 16371/2001 in Appendix B shows the proposed drainage proposals and layout for the site. Soakaway design calculations using Microdrainage are given in Appendix C.

3.5 Foul Water Treatment Design

Flows and Loads 4 (British Water, 2013) states that 'a treatment system for a single house with up to and including 3 bedrooms shall be designed for a minimum population (P) of 5 people.....[add] 1P for each additional bedroom'. To take a conservative approach, it is assumed that the house will have 5 bedrooms, hence the PE will be

$$PE = 5 + 2 = 7.$$

As a result of site testing, it is concluded that the percolation value (V_p) at the site is lower than 15s/mm. For discharges of $\leq 15PE$ to a sub-surface soakaway where $V_p < 15s/mm$, SEPA, 2019 requires that secondary treatment is carried out prior to discharge. Calculation of the predicted daily total flow, BOD and ammoniacal nitrogen production is shown in Table 5.

Table 5: Foul water discharge components using values from Flows and Loads for a standard residential setting.

| | Flow (l/day) | BOD (g/day) | Ammonia as N (g/d) |
|------------|--------------|-------------|--------------------|
| Per person | 150 | 60 | 8 |
| Population | 7 | 7 | 7 |
| Total | 1050 | 420 | 56 |

A PTP capable of treating the discharge, such as the Klargestor BioDisc BA-X, suitable for up to 9PE, which can produce an effluent quality of 8mg/l BOD, 13mg/l SS, 4mg/l Ammonia and 2mg/l Phosphate (www.klargester.co.uk), is recommended.

For discharges of $\leq 15PE$ to land with $V_p < 15s/mm$, SEPA, 2019 recommends a minimum soakaway area of:

$$A (m^2) = 3.6 \times PE$$

$$\text{Hence } A = 3.6 \times 7 = 25.2m^2.$$

A soakaway 6.5m long x 4m wide x 1m deep (surface area 26 m²) is recommended. The proposed foul soakaway area is shown on drawing 16371/2001. Foul drainage calculations are given in Appendix D.

3.6 Maintenance

All the components of the proposed foul and surface water system associated with the development including pipes and chambers, along with the sewage treatment plant and drainage soakaways, will be owned and maintained by the property owner. This will be inspected on an annual basis. If blockage is identified or suspected, within the system, it will be cleaned out without delay. In the event of a system failure, it will be replaced with a similar specification.

4.0 CONCLUSION

The result of testing carried out on the site indicates that the site is suitable for soakaway drainage. This method will be used, in line with the Scottish Water design hierarchy for surface water (Scottish Water, 2017).

Surface runoff from the roof will be directed to a stone-filled subsurface soakaway, sized to accommodate to 30-year return period (3.3% probability) event + 35% climate change allowance. The soakaway has been designed with reference to a proprietary system: calculations using MicroDrainage show that the required soakaway dimensions are 5m long x 4m wide x 1m deep. The Simple Index Approach (CIRIA, 2016) has been applied to ensure that adequate mitigation is applied for any contaminants present in the runoff.

The driveway and parking area will be formed of a permeable material to allow direct infiltration.

Foul effluent will be treated by a packaged treatment plant before being directed to a sub-surface soakaway, in accordance with SEPA, 2019.

5.0 REFERENCES

BGS GeoIndex www.bgs.ac.uk, viewed 19th August 2021

British Water, 2013, *Code of Practice Flows and Loads – 4: Sizing Criteria, Treatment Capacity for Sewage Treatment Systems*, ISBN 978-1-903481-10-3

BSI, 2013: *Drain and Sewer systems outside buildings*, BS EN 752:2008 incorporating Corrigenda October 2009 and November 2013, British Standards Institution, ISBN 978-0-580-84887-2.

Building (Scotland) Regulations Schedule 5. Scottish Statutory Instrument 2004 no. 406, Building and Buildings.

CIRIA, 2016: C753 *The SuDS Manual*, RP992, ISBN 978-0-86017-760-9, version 5 including errata, 2016, CIRIA, London.

MicroDrainage, Version 2017.1.2, XP Solutions, distributed by Innovyze.

Moray Council, 2020, *Supplementary guidance: Flood Risk and Drainage Impact Assessment for New Developments*. Moray Local Development Plan 2020;

NIEA, SEPA and NRW, 2017: Guideline for Pollution Prevention 4: *Treatment and disposal of wastewater where there is no connection to the public foul sewer*.

Scottish Executive Development Department (2001) Planning Advice Note (PAN) 61: *Planning and Sustainable Urban Drainage Systems*.

Scottish Government, 2014 (updated Dec. 2020), Scottish Planning Policy: *Managing Flood Risk and Drainage*, ISBN 978-1-78412-567-7, The Scottish Government, St. Andrew's House, Edinburgh.

Scottish Government Online Planning Advice on Flood Risk 2015. <https://www.gov.scot/publications/flood-risk-planning-advice/>, viewed on 22nd August 2021.

Scottish Water, 2017: Standard advice note and process guidance: *Surface Water Policy*, SWSWP1 01/17, downloaded 9th August 2021 from <https://swazurecms.scottishwater.co.uk/>.

Scottish Water, 2018, *Sewers for Scotland – A technical specification for the design and construction of sewerage infrastructure*. Version 4.0, October 2018.

SEPA, 2019, Water Use Regulatory Method (WAT-RM-04) '*Indirect Sewage Discharges to Groundwater*,' version 7.3, October 2019.

SSI 2011 No. 209, Environmental Protection: Water: *The Water Environment (Controlled Activities) (Scotland) Regulations 2011*, as amended.

SSI 2017 No. 389, Environmental Protection: Water: *The Water Environment (Miscellaneous) (Scotland) Regulations 2017*.

SuDS Working Party, 2016: *Water Assessment and Drainage Assessment Guide - A guidance document for developers, planners and others involved in water and drainage*. ISBN 978-1-901322-99-6, undated document, published 2016.

APPENDIX A

Pollution Hazard Indices

Table 26.2 – Pollution Hazard Indices for Different Land Use Classifications (Extract from CIRIA SuDs Manual)

| Land Use | Pollution hazard level | Total Suspended Solids (TSS) | Metals | Hydrocarbons |
|--|------------------------|------------------------------|--|--------------|
| Residential Roofs | Very low | 0.2 | | |
| Other roofs (typically commercial/ industrial) | Low | 0.3 | 0.2 (up to 0.8 where there is potential for metals to leach from the roof) | 0.05 |
| Individual property driveways, residential car parks, low-traffic roads (e.g., cul-de-sacs, homezones and general access roads) and non-residential car parking with infrequent change e.g., schools, offices i.e., < 300 traffic movements per day. | Low | 0.5 | 0.4 | 0.4 |

APPENDIX B

Development Drawings

- 16371/2001 – Drainage Layout

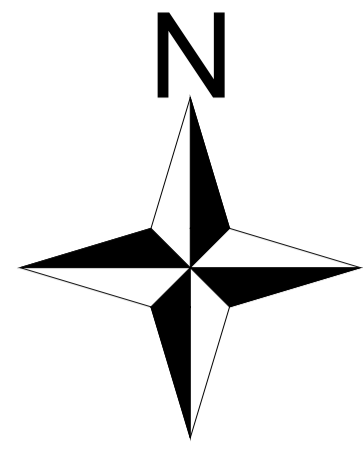

DRAINAGE LAYOUT
SCALE 1:250

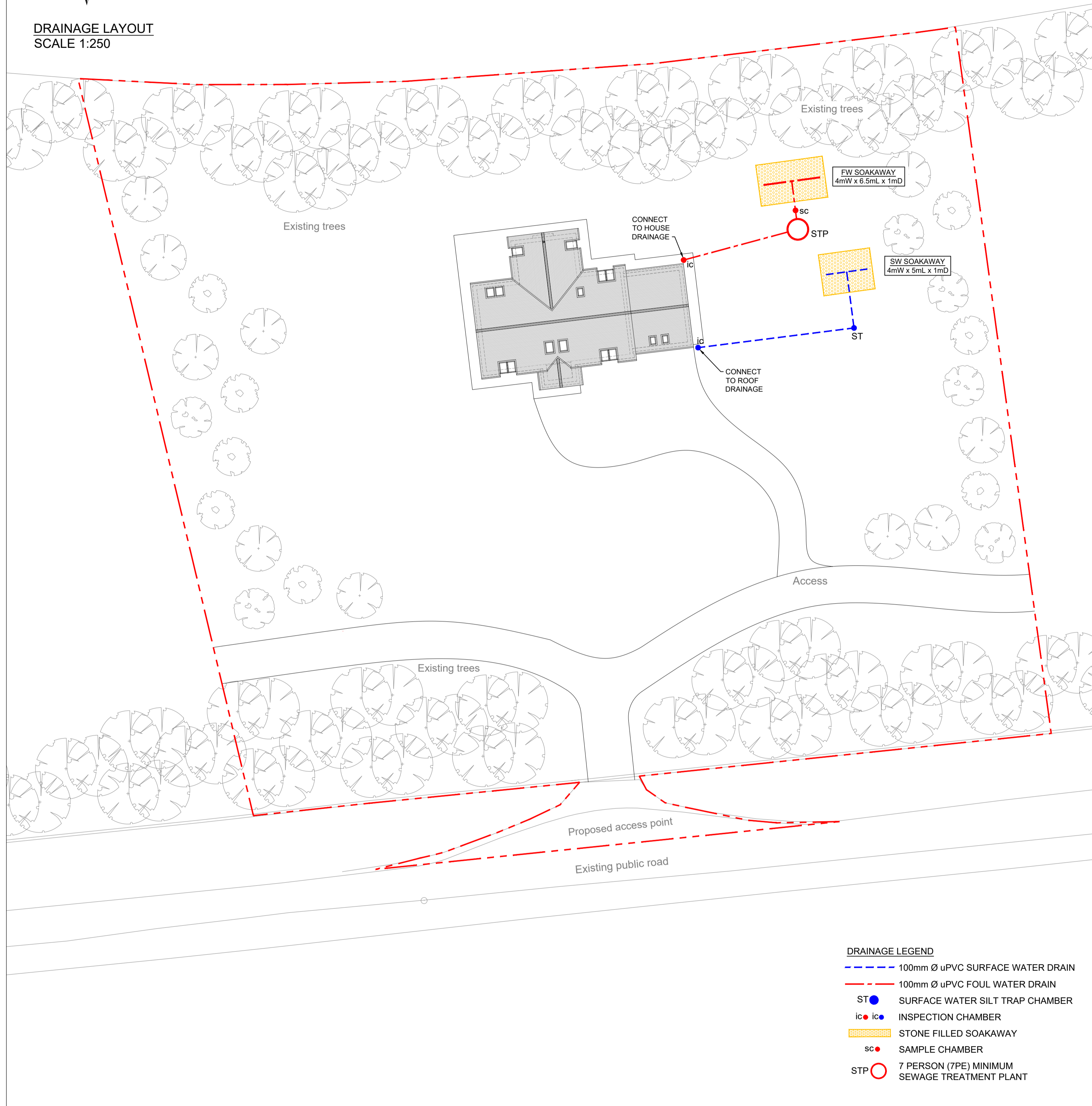

- DRAINAGE LEGEND**
- 100mm Ø uPVC SURFACE WATER DRAIN
 - 100mm Ø uPVC FOUL WATER DRAIN
 - SURFACE WATER SILT TRAP CHAMBER
 - INSPECTION CHAMBER
 - STONE FILLED SOAKAWAY
 - SAMPLE CHAMBER
 - 7 PERSON (7PE) MINIMUM SEWAGE TREATMENT PLANT

Note

- All works by the contractors should be carried out in strict accordance with the 'Health and Safety Act' requirements.
- All works to be in accordance with the current 'Building Standards (Scotland) Regulations' and all relevant British and European Standard Specifications and Codes of Practice.
- All dimensions in millimeters unless otherwise noted.
- No dimensions are to be scaled from this drawing.
- All dimensions and levels shown to be checked on site by the Principal Contractor.
- The Principal Contractor is to ensure they are aware of the implications of changes which either they or the other contractors make and the engineer notified of any such changes.

WHERE ANY DIMENSIONS, GROUND CONDITIONS, EXISTING STRUCTURES VARY ON SITE, WORK TO BE STOPPED AND THE STRUCTURAL ENGINEER TO BE NOTIFIED IMMEDIATELY

- Drainage Note**
- All drainage to be installed in accordance with the Sewers for Scotland - 4th Edition.
 - This drawing is to be read in conjunction with relevant specification and all other relevant drawings issued by the engineer and architect.
 - All gully tails and branch connection to disconnecting manholes to be 150mm Ø suitably encased in concrete.
 - All pipes with less than 1.2m cover below carriageways or 0.9m cover below landscaped areas to be encased in 150mm concrete surround.
 - All falls from disconnecting manholes to be laid at a min. gradient of 1:60.
 - All building drainage to be laid at a min. gradient of 1:100 UNO.
 - All unplasticised PVC pipes, joints and fittings for gravity sewers shall comply with BS 4660 and BS EN 1401-1.
 - Verified clay pipes and fittings for sewers shall have flexible mechanical joints. Pipes for foul sewers and surface water sewers shall comply with BS EN 295 and BS 65.
 - Unreinforced and reinforced concrete pipes and fittings with flexible joints shall comply with BS 5911 and BS EN 1916.
 - All precast units to be reinforced and to comply with BS EN 1917: 2002.
 - Soakaways and filter trenches to be minimum 5m clear of foundations and site boundary.
 - All connections to drainage pipes to be via 45° oblique junction in direction of flow.
 - Drains passing through mass concrete shall be wrapped and drains passing through reinforced concrete shall be sleeved in accordance with the engineer's relevant specification and/or drawings.

- Sewage Treatment Plant Note**
- Sewage Treatment Plant installation, discharge and maintenance to comply with the required specification and standards set-out in the relevant guidelines, namely:
- Building Standards Domestic Technical Handbook Sections 3.7 and 3.8
 - SEPA Guidance for Sewage Discharges to Surface Waters (WAT-RM-03)
 - The Water Environment (Controlled Activities) (Scotland) Regulations 2011, as amended.

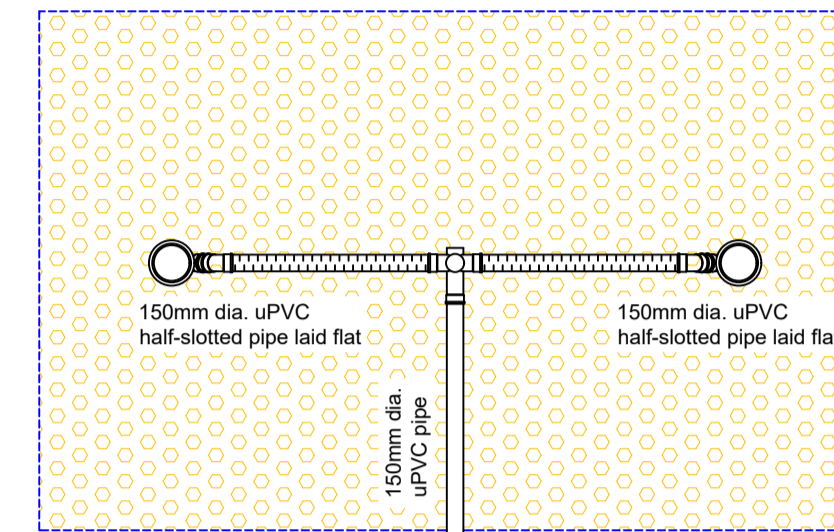

TYPICAL PLAN ON SOAKAWAY
Scale 1:50

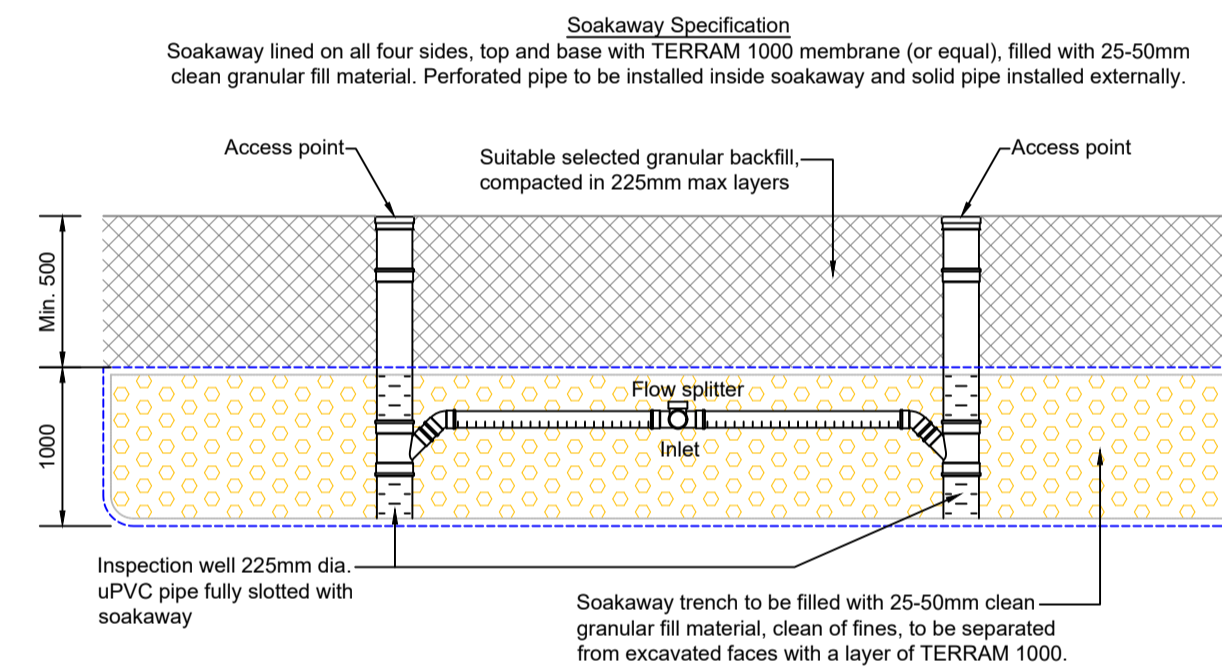

TYPICAL SECTION THROUGH SOAKAWAY
Scale 1:50

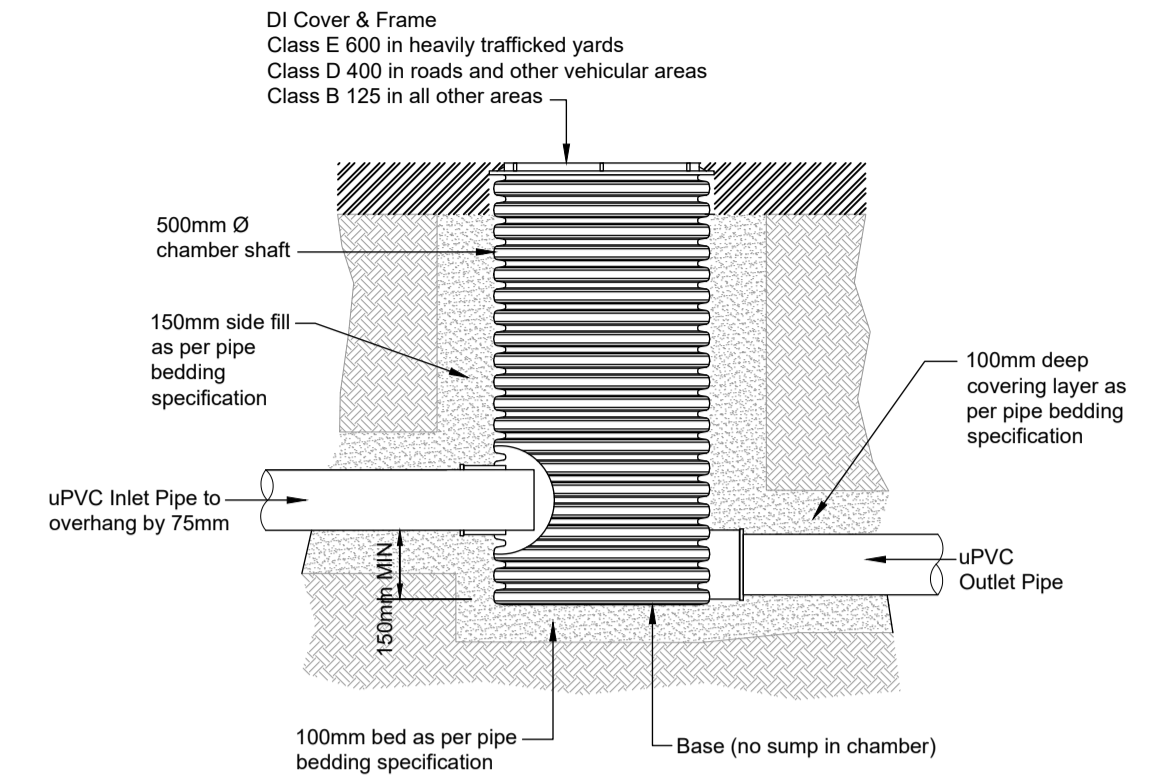

NON-ENTRY SAMPLE CHAMBER
Scale 1:20

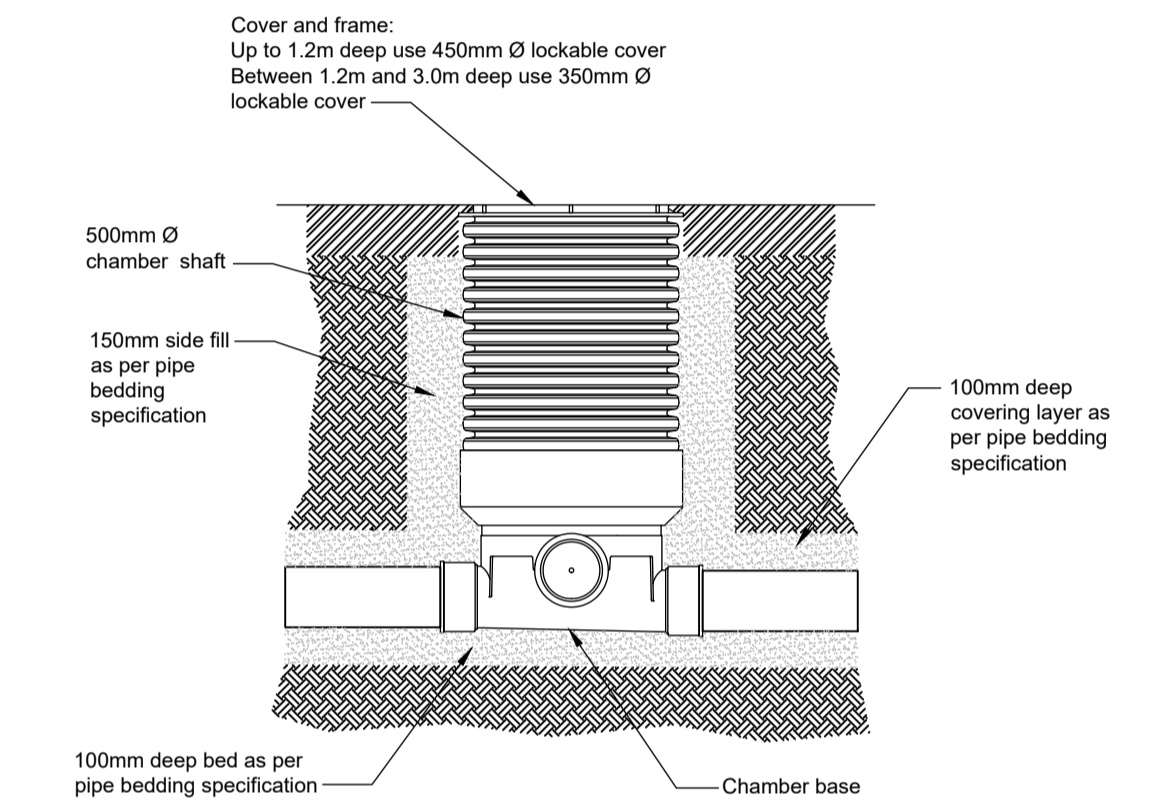

INSPECTION CHAMBER
Scale 1:20

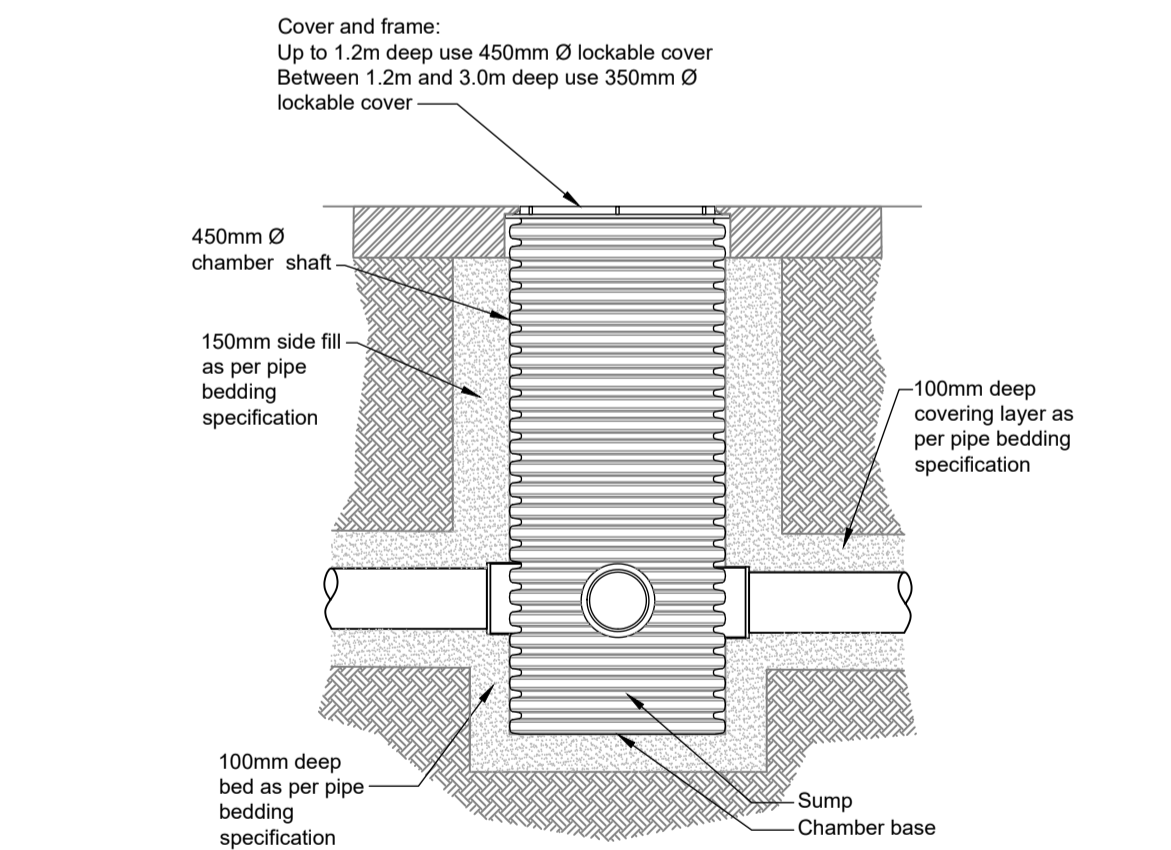

TYPICAL SILT TRAP CHAMBER
Scale 1:20

© Drawing Copyright to MacLeod & Jordan Ltd

| Revision | Date | By | Comments |
|----------|------|----|----------|
| | | | |
| | | | |
| | | | |
| | | | |
| | | | |
| | | | |
| | | | |
| | | | |
| | | | |

| | |
|---------|---|
| Client | MR & MRS S HANCOX |
| Project | PLOT 3, LAND AT STRATTON WOOD, HILL OF ORBLISTON, FOCHABERS, IV32 7LN |
| Title | PROPOSED DRAINAGE LAYOUT AND DETAILS |

| | |
|-------------|-------------|
| Date | 29.09.21 |
| Scale at A1 | AS SHOWN |
| Drawn By | FM |
| Checked By | RM |
| Status | INFORMATION |

| | | | |
|--|-------|--|---|
| THE INFORMATION CONTAINED ON THIS DRAWING IS CONFIDENTIAL UNLESS AGREED OTHERWISE (BY A RELEVANT CONTRACT OR IN WRITING) THIS DRAWING SHALL REMAIN THE PROPERTY OF MACLEOD & JORDAN LTD. WITHOUT PRIOR AGREEMENT THE DRAWING SHOULD NOT BE USED FOR ANY OTHER PURPOSE THAN THAT AGREED, NOR SHOULD THE DRAWING BE REPRODUCED IN WHOLE, OR PART, OR PASSED ON TO ANY THIRD PARTY. | | | |
| MACLEOD JORDAN | | 16 Albert Street Aberdeen AB25 1XQ | Tel: (01224) 646 555 info@macleodjordan.co.uk www.macleodjordan.co.uk |
| Project No. | 16371 | Drawing No. | 2001 |
| Rev. | - | | |

APPENDIX C

Surface Water Soakaway Calculations

- Calculations for 10-year return period
- Calculations for 30-year return period

| | | |
|--|---|---|
| MacLeod & Jordan | | Page 1 |
| 16 Albert Street Aberdeen AB25 1XQ | 16371 PLOT 3, STRATTON WOOD FOCHABERS, IV32 7LN |  |
| Date 06/10/2021 14:27 File 16371 stone soakaway fm... | Designed by MN Checked by RM | |
| Innovyze | Source Control 2017.1.2 | |

Summary of Results for 10 year Return Period (+35%)

Half Drain Time : 32 minutes.

| Storm Event | Max Level (m) | Max Depth (m) | Max Infiltration (l/s) | Max Volume (m ³) | Status |
|------------------|---------------|---------------|------------------------|------------------------------|--------|
| 15 min Winter | 98.951 | 0.451 | 1.0 | 2.7 | O K |
| 30 min Winter | 99.055 | 0.555 | 1.1 | 3.3 | O K |
| 60 min Winter | 99.110 | 0.610 | 1.1 | 3.7 | O K |
| 120 min Winter | 99.067 | 0.567 | 1.1 | 3.4 | O K |
| 180 min Winter | 98.994 | 0.494 | 1.1 | 3.0 | O K |
| 240 min Winter | 98.921 | 0.421 | 1.0 | 2.5 | O K |
| 360 min Winter | 98.790 | 0.290 | 0.9 | 1.7 | O K |
| 480 min Winter | 98.686 | 0.186 | 0.9 | 1.1 | O K |
| 600 min Winter | 98.609 | 0.109 | 0.8 | 0.7 | O K |
| 720 min Winter | 98.558 | 0.058 | 0.8 | 0.3 | O K |
| 960 min Winter | 98.542 | 0.042 | 0.6 | 0.3 | O K |
| 1440 min Winter | 98.532 | 0.032 | 0.5 | 0.2 | O K |
| 2160 min Winter | 98.523 | 0.023 | 0.4 | 0.1 | O K |
| 2880 min Winter | 98.519 | 0.019 | 0.3 | 0.1 | O K |
| 4320 min Winter | 98.514 | 0.014 | 0.2 | 0.1 | O K |
| 5760 min Winter | 98.512 | 0.012 | 0.2 | 0.1 | O K |
| 7200 min Winter | 98.510 | 0.010 | 0.2 | 0.1 | O K |
| 8640 min Winter | 98.509 | 0.009 | 0.1 | 0.1 | O K |
| 10080 min Winter | 98.508 | 0.008 | 0.1 | 0.0 | O K |

| Storm Event | Rain (mm/hr) | Flooded Volume (m ³) | Time-Peak (mins) |
|------------------|--------------|----------------------------------|------------------|
| 15 min Winter | 68.392 | 0.0 | 20 |
| 30 min Winter | 47.566 | 0.0 | 33 |
| 60 min Winter | 31.813 | 0.0 | 52 |
| 120 min Winter | 20.131 | 0.0 | 90 |
| 180 min Winter | 15.233 | 0.0 | 124 |
| 240 min Winter | 12.452 | 0.0 | 160 |
| 360 min Winter | 9.334 | 0.0 | 224 |
| 480 min Winter | 7.591 | 0.0 | 284 |
| 600 min Winter | 6.460 | 0.0 | 340 |
| 720 min Winter | 5.659 | 0.0 | 386 |
| 960 min Winter | 4.588 | 0.0 | 494 |
| 1440 min Winter | 3.407 | 0.0 | 724 |
| 2160 min Winter | 2.525 | 0.0 | 1104 |
| 2880 min Winter | 2.044 | 0.0 | 1456 |
| 4320 min Winter | 1.526 | 0.0 | 2148 |
| 5760 min Winter | 1.251 | 0.0 | 2896 |
| 7200 min Winter | 1.082 | 0.0 | 3680 |
| 8640 min Winter | 0.967 | 0.0 | 4376 |
| 10080 min Winter | 0.884 | 0.0 | 4968 |

| | |
|--|---|
| 16 Albert Street Aberdeen AB25 1XQ | 16371 PLOT 3, STRATTON WOOD FOCHABERS, IV32 7LN |
|--|---|



| | |
|--|---------------------------------|
| Date 06/10/2021 14:27 File 16371 stone soakaway fm... | Designed by MN Checked by RM |
|--|---------------------------------|

| | |
|----------|-------------------------|
| Innovyze | Source Control 2017.1.2 |
|----------|-------------------------|

Rainfall Details

| | |
|-----------------------|---------------------------------|
| Rainfall Model | FEH |
| Return Period (years) | 10 |
| FEH Rainfall Version | 2013 |
| Site Location | GB 330026 858225 NJ 30026 58225 |
| Data Type | Point |
| Summer Storms | No |
| Winter Storms | Yes |
| Cv (Summer) | 0.750 |
| Cv (Winter) | 0.840 |
| Shortest Storm (mins) | 15 |
| Longest Storm (mins) | 10080 |
| Climate Change % | +35 |

Time Area Diagram

Total Area (ha) 0.024

| Time (mins) | Area | Time (mins) | Area |
|-------------|---------|-------------|---------|
| From: | To: | From: | To: |
| | (ha) | | (ha) |
| 0 | 4 0.000 | 4 | 8 0.024 |

| | | |
|--|---|---|
| MacLeod & Jordan | | Page 3 |
| 16 Albert Street Aberdeen AB25 1XQ | 16371 PLOT 3, STRATTON WOOD FOCHABERS, IV32 7LN |  |
| Date 06/10/2021 14:27 File 16371 stone soakaway fm... | Designed by MN Checked by RM | |
| Innovyze | Source Control 2017.1.2 | |

Model Details

Storage is Online Cover Level (m) 100.000

Trench Soakaway Structure

| | | | |
|--------------------------------------|---------|----------------------------|-------|
| Infiltration Coefficient Base (m/hr) | 0.26400 | Trench Width (m) | 5.0 |
| Infiltration Coefficient Side (m/hr) | 0.26400 | Trench Length (m) | 4.0 |
| Safety Factor | 2.0 | Slope (1:X) | 0.0 |
| Porosity | 0.30 | Cap Volume Depth (m) | 1.000 |
| Invert Level (m) | 98.500 | Cap Infiltration Depth (m) | 0.000 |

| | | |
|--|---|---|
| MacLeod & Jordan | | Page 1 |
| 16 Albert Street Aberdeen AB25 1XQ | 16371 PLOT 3, STRATTON WOOD FOCHABERS, IV32 7LN |  |
| Date 06/10/2021 14:26 File 16371 stone soakaway fm... | Designed by MN Checked by RM | |
| Innovyze | Source Control 2017.1.2 | |

Summary of Results for 30 year Return Period (+35%)

Half Drain Time : 43 minutes.

| Storm Event | Max Level (m) | Max Depth (m) | Max Infiltration (l/s) | Max Volume (m ³) | Status |
|------------------|---------------|---------------|------------------------|------------------------------|--------|
| 15 min Winter | 99.169 | 0.669 | 1.2 | 4.0 | O K |
| 30 min Winter | 99.350 | 0.850 | 1.3 | 5.1 | O K |
| 60 min Winter | 99.461 | 0.961 | 1.4 | 5.8 | O K |
| 120 min Winter | 99.390 | 0.890 | 1.3 | 5.3 | O K |
| 180 min Winter | 99.291 | 0.791 | 1.3 | 4.7 | O K |
| 240 min Winter | 99.194 | 0.694 | 1.2 | 4.2 | O K |
| 360 min Winter | 99.024 | 0.524 | 1.1 | 3.1 | O K |
| 480 min Winter | 98.886 | 0.386 | 1.0 | 2.3 | O K |
| 600 min Winter | 98.775 | 0.275 | 0.9 | 1.7 | O K |
| 720 min Winter | 98.686 | 0.186 | 0.9 | 1.1 | O K |
| 960 min Winter | 98.566 | 0.066 | 0.8 | 0.4 | O K |
| 1440 min Winter | 98.539 | 0.039 | 0.6 | 0.2 | O K |
| 2160 min Winter | 98.529 | 0.029 | 0.4 | 0.2 | O K |
| 2880 min Winter | 98.523 | 0.023 | 0.4 | 0.1 | O K |
| 4320 min Winter | 98.518 | 0.018 | 0.3 | 0.1 | O K |
| 5760 min Winter | 98.514 | 0.014 | 0.2 | 0.1 | O K |
| 7200 min Winter | 98.513 | 0.013 | 0.2 | 0.1 | O K |
| 8640 min Winter | 98.511 | 0.011 | 0.2 | 0.1 | O K |
| 10080 min Winter | 98.510 | 0.010 | 0.2 | 0.1 | O K |

| Storm Event | Rain (mm/hr) | Flooded Volume (m ³) | Time-Peak (mins) |
|------------------|--------------|----------------------------------|------------------|
| 15 min Winter | 96.646 | 0.0 | 21 |
| 30 min Winter | 67.571 | 0.0 | 34 |
| 60 min Winter | 45.250 | 0.0 | 52 |
| 120 min Winter | 27.477 | 0.0 | 92 |
| 180 min Winter | 20.361 | 0.0 | 128 |
| 240 min Winter | 16.421 | 0.0 | 164 |
| 360 min Winter | 12.103 | 0.0 | 230 |
| 480 min Winter | 9.733 | 0.0 | 294 |
| 600 min Winter | 8.216 | 0.0 | 356 |
| 720 min Winter | 7.152 | 0.0 | 416 |
| 960 min Winter | 5.746 | 0.0 | 514 |
| 1440 min Winter | 4.223 | 0.0 | 738 |
| 2160 min Winter | 3.112 | 0.0 | 1104 |
| 2880 min Winter | 2.516 | 0.0 | 1444 |
| 4320 min Winter | 1.879 | 0.0 | 2180 |
| 5760 min Winter | 1.542 | 0.0 | 2976 |
| 7200 min Winter | 1.334 | 0.0 | 3592 |
| 8640 min Winter | 1.193 | 0.0 | 4352 |
| 10080 min Winter | 1.090 | 0.0 | 5104 |

| | |
|--|---|
| 16 Albert Street Aberdeen AB25 1XQ | 16371 PLOT 3, STRATTON WOOD FOCHABERS, IV32 7LN |
|--|---|



| | |
|--|---------------------------------|
| Date 06/10/2021 14:26 File 16371 stone soakaway fm... | Designed by MN Checked by RM |
|--|---------------------------------|

| | |
|----------|-------------------------|
| Innovyze | Source Control 2017.1.2 |
|----------|-------------------------|

Rainfall Details

| | |
|-----------------------|---------------------------------|
| Rainfall Model | FEH |
| Return Period (years) | 30 |
| FEH Rainfall Version | 2013 |
| Site Location | GB 330026 858225 NJ 30026 58225 |
| Data Type | Point |
| Summer Storms | No |
| Winter Storms | Yes |
| Cv (Summer) | 0.750 |
| Cv (Winter) | 0.840 |
| Shortest Storm (mins) | 15 |
| Longest Storm (mins) | 10080 |
| Climate Change % | +35 |

Time Area Diagram

Total Area (ha) 0.024

| Time (mins) | Area | Time (mins) | Area |
|-------------|----------|-------------|----------|
| From: | To: (ha) | From: | To: (ha) |
| 0 | 4 0.000 | 4 | 8 0.024 |

| | | |
|--|---|---|
| MacLeod & Jordan | | Page 3 |
| 16 Albert Street Aberdeen AB25 1XQ | 16371 PLOT 3, STRATTON WOOD FOCHABERS, IV32 7LN |  |
| Date 06/10/2021 14:26 File 16371 stone soakaway fm... | Designed by MN Checked by RM | |
| Innovyze | Source Control 2017.1.2 | |

Model Details

Storage is Online Cover Level (m) 100.000

Trench Soakaway Structure

| | |
|--|----------------------------------|
| Infiltration Coefficient Base (m/hr) 0.26400 | Trench Width (m) 5.0 |
| Infiltration Coefficient Side (m/hr) 0.26400 | Trench Length (m) 4.0 |
| Safety Factor 2.0 | Slope (1:X) 0.0 |
| Porosity 0.30 | Cap Volume Depth (m) 1.000 |
| Invert Level (m) 98.500 | Cap Infiltration Depth (m) 0.000 |

APPENDIX D

Foul Drainage Calculations

- Sewage Treatment Plant and Soakaway Calculations

**Members'
Ref.****CALCULATIONS****OUTPUT****FOUL DRAINAGE SOAKAWAY**

5 BEDROOM DWELLING THEREFORE PE = 5 + 2 = 7

FROM PERCOLATION TESTING:

VP = (25 x 60 sec) / 110mm = 13.6 sec/mm

VP < 15sec/mm THEREFORE REQUIRES SEWAGE TREATMENT
PLANT WITH FOUL SOAKAWAY

SOAKAWAY

MINIMUM SOAKAWAY AREA A (m2) = PE x 3.6
= 7 x 3.6
= 25.2 m2

THE SOAKAWAY SIZE IS TO BE EQUAL OR GREATER THAN THE
CALCULATED AREA A NOTED ABOVE.

RECOMMENDED SOAKAWAY SIZE: 4 m x 6.5 m = 26 m2.

SEWAGE TREATMENT PLANT

ADOPT SEWAGE TREATMENT PLANT TO SERVE MINIMUM OF 7
PE

THEREFORE:

**ADOPT minimum 7 person (7 PE) Sewage Treatment Plant and
6.5 m long x 4 m wide x 1 m deep soakaway.**



astell associates

arboricultural, ecological
& landscape consultants

8th February 2022

Ref: SWF-2202-TR

Tree Survey Report



Land at Stratton Woods, Fochabers

Client: Samantha Hancox

10 Polston Road, Maryculter
Aberdeen, AB12 5GY
Tel: 01224 734372
www.astellassociates.co.uk
info@astellassociates.co.uk

Tree Survey

Land at Stratton Woods, Fochabers

Contents

| | |
|---|----|
| Summary | 3 |
| Introduction | 3 |
| Scope of Survey | 3 |
| Study Aim | 3 |
| Study Objectives:..... | 3 |
| Limitations | 3 |
| Desk Study | 4 |
| Site Visit and Tree Assessment Methodology | 4 |
| Site Description & Proposed Development | 5 |
| Site Location | 5 |
| Site Description | 5 |
| Development Proposals | 5 |
| Tree Preservation Orders / Conservation Areas | 5 |
| Tree Species in Survey Area | 6 |
| Arboricultural Impact | 6 |
| General | 6 |
| Trees to be felled..... | 6 |
| Tree Protection..... | 7 |
| Underground Service Installation | 7 |
| Bat Roost Potential..... | 7 |
| Badgers | 7 |
| Site Photos | 8 |
| Arboricultural Method Statement | 10 |
| General | 10 |
| Sequence of Operations..... | 10 |
| General Precautions..... | 10 |
| Supervision and Monitoring | 11 |
| Contingency Plans..... | 11 |
| Damage Limitation..... | 11 |
| Appendix A: Tree Schedule..... | 12 |
| Appendix B: Plan of Badger Setts in Stratton Woods | 16 |
| Appendix C: Tree Quality Assessment Chart - Adapted from BS: 5837 20127 | 17 |
| Appendix D: Tree Life Stages from BS: 5837..... | 18 |
| Appendix E: Drawings | 18 |
| Appendix F: Legislation, Guidance and References | 18 |
| Appendix G: Professional Qualifications | 19 |
| Appendix H: Contact Details..... | 19 |
| Appendix I: Protective Barrier & Ground Protection - BS: 5837 - 2012 | 20 |



Tree Survey

Land at Stratton Woods, Fochabers

Summary

The proposal is for the construction of a house, SuDS, and access road in a clearing in an area of plantation coniferous woodland. Only the trees closest to the clearing were surveyed, as these were the only trees potentially affected by the proposals. A total of 71 trees were surveyed. The trees are mostly healthy, mature Scots pine with a few larches and birch interspersed.

Nine trees are to be removed to accommodate development. No trees are to be removed for health and safety.

Introduction

Scope of Survey

Astell Associates have been instructed by John Wink Design on behalf of Samantha Hancox to advise on trees and the constraints on development at Land at Stratton Woods, Fochabers.

This report is intended to accompany the Planning Application as a document supporting the application and demonstrating that the implications of the proposed development on the arboricultural, landscape and cultural (conservation) value of the trees on the site have been fully considered.

Study Aim

The aim is to identify any tree constraints to inform the proposed development of the site..

Study Objectives:

- Map the location and characteristics of the trees and tree groups within and adjacent to the site, which could be affected by the development proposals
- Identify trees which would be removed as part of normal arboricultural management (i.e. dead/unviable trees)
- Assess trees for bat roosting potential
- Identify any constraints or threats which may impact future management of the trees.
- Provide outline management recommendations to designed to retain trees and tree groups on or adjacent to the site

Limitations

- This is a preliminary assessment from ground level and observations have been made solely from visual inspection for the purposes of assessment for planning and the proposed development.
- No invasive or other detailed internal decay detection instruments have been used in assessing trunk condition.
- No soil samples have been taken and no soil analysis carried out.



- The conclusions relate to conditions found at the time of inspection. The recommendations contained within this report (Tree Schedule) are valid for a period of one year only.
- Any significant alteration to the site that may affect the trees that are present (including level changes, hydrological changes, extreme climatic events or other site works) may necessitate a re-assessment of the trees and the site.
- It should be noted that this survey is not a tree safety inspection. It is carried out in order to inform the planning process

Desk Study

A desk study has been carried out to ascertain any Tree Protection Orders or Statutory designations for the area (Ancient Woodland or National Forest Inventory).

Site Visit and Tree Assessment Methodology

- A site visit was undertaken on 12 January 2022 by Aaron Meijer.
- Trees have been surveyed from ground level with binoculars to survey features at height.
- The Visual Tree Assessment method (Mattheck and Breloer, 1994) has been used to assess the trees.
- Standards and methodology from BS5837:2012 – ‘Trees in relation to design, demolition and construction – Recommendations’ (BSI, 2012) and Arboricultural Association Guidance Note 7 ‘Tree Surveys: A Guide to Good Practice’ have been used, along with the Aberdeen Local Development Plan Supplementary Guidance: ‘Trees and Woodlands’ (2017)
- A Hypsometer has been used to establish tree heights, with visual estimates being used for trees in close proximity.
- All trees with a diameter of over 12cm (15cm in woodland) have been numbered with plastic ‘letratag’ numbers.
- Trees have been surveyed for tree species, height, number of stems, stem diameter, branch spread, tree category and suitability for retention.
- Trees have been surveyed from ground level for bat roosting potential to inform of any further survey work that may be required on trees affected by the proposals.
- Canopy spread has been estimated by pacing and dimensions given to N, S, E & W.
- Where trees are growing as a close grown community of the same species, they may be described as a group rather than individually detailed.
- The trees have been positioned by a topographic survey carried out by John Wink Design
- Details of surveyed trees are provided in The Tree Survey Schedule, Appendix A. Refer to drawing SWF-2202-AA, which is a plan showing the location of each tree and its arboricultural tree category.



Site Description & Proposed Development

Site Location

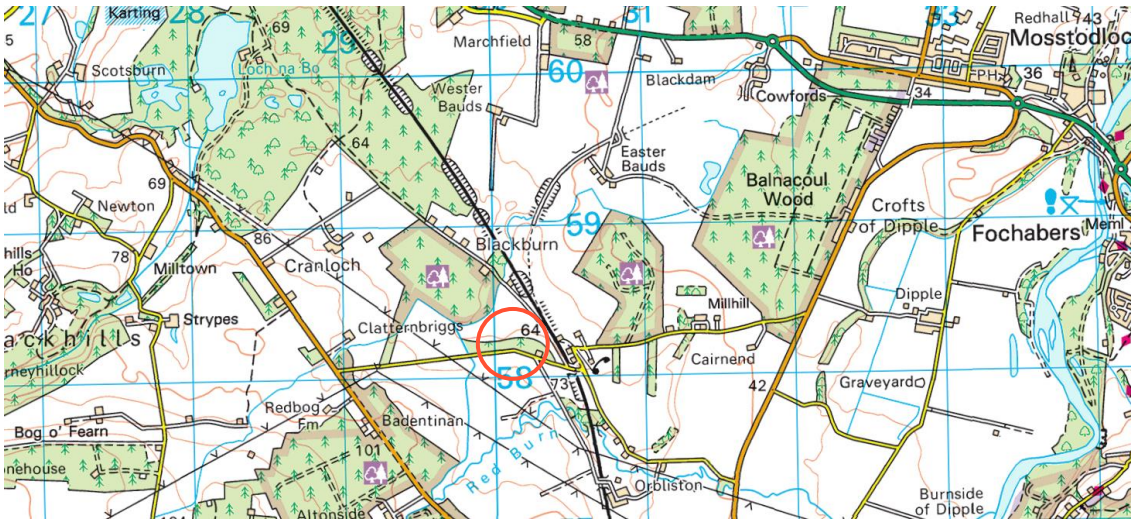

Figure 1. Site location outlined in red. Grid ref: NJ300581. Postcode: IV32 7LN.

Site Description



Figure 2. Aerial photo of site with site boundary marked in red.

The site is an area of plantation Scots pine woodland with a few birch and larch interspersed. There is a clearing in the centre of the site with several piles of logs. There are forestry tracks along the north and south boundary of the site.

Development Proposals

The proposal is for the construction of a house, along with associated access road and SUDS.

Tree Preservation Orders / Conservation Areas

The site is listed on the National Forest Inventory as 'Conifer'.



Tree Species in Survey Area

| Common Name | Scientific name | No |
|-------------|-----------------------|----|
| Birch | <i>Betula pendula</i> | 1 |
| Larch | <i>Larix decidua</i> | 3 |

| Common Name | Scientific name | No |
|-------------|-------------------------|----|
| Scots pine | <i>Pinus sylvestris</i> | 67 |

Arboricultural Impact

General

The proposed house is to be constructed in an existing clearing in the Scots pine plantation woodland and no trees will need to be felled for the proposed house. The SUDs and access road will require the felling of 5 trees, three B class and two C class Scots pine. The Scots pine trees on the site are tall thin trees with canopy at height, which have been planted as a commercial crop and are near their destined felling size.

Topsoil has been piled into a mound between trees 47 and 50. This mound should be removed as it is overburdening the roots of trees 40, and 47. This soil overburden could eventually kill the trees making them a potential danger to the proposed house.

As part of the proposals, additional trees and shrubs are to be planted. These trees will constitute native species such as Scots pine, birch, and holly, and will be planted with a density of 1 per square metre.

Trees to be felled

The following trees will be felled for the proposed development:

| | | | | |
|---------------|---------------|---------------|---------------|---------------|
| 50 Scots Pine | 51 Scots Pine | 52 Scots Pine | 53 Larch | 54 Scots Pine |
| 55 Scots Pine | 56 Scots Pine | 60 Scots Pine | 61 Scots Pine | |

No trees will be felled for woodland management or health and safety:

The tree schedule with details of each tree is given in Appendix A



Tree Protection

All trees shown as retained within the tree table and site plans that accompany this report will be protected in accordance with British Standard BS: 5837 2012 - Trees in Relation to Design, Demolition and Construction, prior to the commencement of any development activity at the site.

Tree Protection fencing will be erected in the location shown in Drawing SWF-2202-TP. Details of fencing can be found in Appendix I.

Tree felling and remedial tree works should be undertaken before this fencing is erected.

After any tree felling and remedial tree works have been completed, the tree protection fencing must be erected before any demolition, site preparation or construction work commences, i.e. as the first operation on site following Planning Approval.

Underground Service Installation

Details of any proposed service runs associated with the proposed development have not been provided. However, it is likely the services will be situated adjacent to the proposed access road. It is possible to avoid the root plate of the retained trees but this will need to be assessed at the detailed planning stage..

Bat Roost Potential

As part of the tree survey, all trees were surveyed from ground level for features which indicate that they could have bat roosting potential. This includes features such as holes and cavities, cracks / splits in major limbs, loose bark. Such features are more commonly found on mature or veteran trees.

None of the surveyed trees has bat roosting potential, when surveyed from ground level.

Badgers

During the tree survey, mammal paths were discovered around the site. These were followed and several badger setts were identified in Stratton Woods.

Badgers are given protection under the protection of Badgers Act 1992, as amended by the Nature Conservation (Scotland) Act 2004. The exclusion zone for badgers recommended by NatureScot is 30 m away from a sett. Two setts were found within the 30 m exclusion zone. These setts were disused, and it appeared that they have been for some time. No recent digging marks were found and the entrance holes were filled with twigs. Furthermore, although these setts are within 30 m of the site boundary, they are over 30 m outwith the area of the proposed house.

Two active badger setts were found in a bank 110 m west of the site, on the edge of Stratton Woods. There are well outwith the NatureScot recommended exclusion zone. For a plan of identified badger setts in Stratton Woods, see Appendix B.

There are no active badger setts within 30m or close by the development site. The proposed development site will have no impact on badgers.



Site Photos



Photo 1:
View southwest,
showing the trees in
the southwest of
the site, adjacent to
the site access.



Photo 2:
View east, showing
the trees along the
west edge of the
clearing.



Photo 3:
View northeast,
showing the trees
around the soil pile.
Tree 50 is to be
felled.





Photo 4:
View north,
showing the
clearing in the
centre of the site.
This is the location
of the proposed
house. Trees 53 – 56
are to be felled.



Photo 5:
View southeast,
showing the trees in
the southeast
corner of the site.
Tree 61 is to be
felled.



Photo 6:
Active badger sett
in the west of
Stratton Woods, 110
m outwith the site.



Photo 7:
Disused badger sett
within 30 m of the
site boundary.

Arboricultural Method Statement

General

This is an Arboricultural Method Statement highlighting the sequence of operations that will be undertaken.

This section sets out the basis for all proposed works in relation to the proposed development in proximity to trees located within the development site boundary and for those trees outside the development site boundary where they overhang the site or where their RPAs extend into the site.

Copies of this Arboricultural Method Statement document will be available for inspection on site and will form the basis of the management of all works relating to the trees on the site for the Site Agent/Project Manager following commencement of the project.

The developer will inform the Local Planning Authority of the Arboricultural Consultant overseeing and monitoring the works related to the trees retained on site and will notify the Local Planning Authority within twenty-four hours if the Arboricultural Consultant is replaced.

Sequence of Operations

1. All tree works detailed on the tree schedule (Appendix A and Arboricultural Impact section) will be carried out to BS:3998.
2. The tree protection fences will be marked out by the Arboricultural Consultant together with the site manager, all as per plan SWF-2202-TP.
3. The tree protection fences will be erected by fencing contractors.
4. The tree protection fences will consist of a scaffold framework in accordance with Figure 2 of BS 5837:2012 (Appendix I). Alternatively wooden posts can be sunk into the ground for 75cm and deer netting (Rylock) attached to a height of 1.8m. This fencing will have horizontal battens at 1.0 and 1.8m and will have diagonal supports where necessary.
5. The tree protection fencing will be inspected by the arboricultural consultant and its correct position and construction will be confirmed in writing to the architect and client.
6. Protective barrier site notices (similar to those presented in Appendix I) will be attached to the exterior of the tree protection fencing where they can be read easily by site personnel.
7. The tree protection fences will remain in place until completion of the main construction phase.

General Precautions

8. No materials which are likely to have an adverse effect on tree health will be stored or discharged within 10m of the base of a tree which is to be retained. Further considerations will be given to storage of materials upslope of retained trees to minimise the risk of spillages leaching down-slope and contaminating the root protection area of a tree. Such materials include, but are not limited to:
 - Oil
 - Bitumen
 - Cement
9. No fires will be lit within 20m of the base of any tree which is to be retained.



10. Concrete mixing will not take place within 10m of the base of any tree which is to be retained.
11. Other than works detailed in this method statement, or approved by the local planning authority, no works (including the storage or dumping of materials, or the storage or operation of plant or machinery) shall take place within the construction exclusion zones set out by the tree protection fences.

Supervision and Monitoring

An Arboricultural Consultant will be responsible for monitoring of all operations relating to arboricultural issues and will issue a written confirmation of completion of the following operations:

- All tree works.
- The erection of tree protection fences in accordance with plan SWF-2202-TP.
- The excavation of trenches for any services close to trees.

A record of site visits completed by the arboricultural consultant will be maintained for inspection on site, and copies will be forwarded to the project manager.

Any operations within the Construction Exclusion Zones of retained trees including the dismantling and erection of tree protection fencing will be overseen and supervised by the appointed arboricultural consultant.

Contingency Plans

In the event of unforeseen incidents occurring which may adversely affect or impact the welfare or security of trees, the site manager will inform the Arboricultural Consultant at the earliest opportunity, and not more than one working day following the incident.

The arboricultural consultant will visit the site to inspect and assess the conditions and make appropriate recommendations. The Local Planning Authority Tree Officer will be informed by the Arboricultural Consultant of such incidents and recommendations will be submitted for approval by the Local Planning Authority.

A record of such incidents and recommendations shall be maintained by the Arboricultural Consultant. Incidents which merit such contingency plans include:

- Accidental/unauthorized damage to the limbs, roots, or trunk of trees
- The spillage of chemicals within or adjacent to a root protection area
- The discharge of toxic materials/waste within or adjacent to a root protection area
- The unscheduled or unsupervised breaching of the tree protection fence

Damage Limitation

Any operations within the Construction Exclusion Zones of retained trees including the dismantling and erection of tree protection fencing will be overseen and supervised by the appointed arboricultural consultant.

Where excavation is required within the Root Protection Area, this will be undertaken by hand, from within the footprint of the plot and should be overseen by the appointed arboricultural consultant.



Appendix A: Tree Schedule

| No | Species | Dia at 1.5m (cm) | Canopy Radius (m) | | | | Height (m) | RPA (m) | Age | Class | Description | Action |
|----|------------|------------------|-------------------|---|---|---|------------|---------|-----|-------|---|---------|
| | | | N | S | E | W | | | | | | |
| 1 | Scots Pine | 30 | 2 | 2 | 2 | 1 | 12 | 3.6 | M | C | Chain wrapped around stem has done significant damage to bark, appears healthy. | Retain. |
| 2 | Scots Pine | 32 | 2 | 2 | 2 | 2 | 11 | 3.8 | M | B | Tree has a slight lean south, appears healthy. | Retain. |
| 3 | Scots Pine | 45 | 2 | 3 | 5 | 1 | 17 | 5.4 | M | B | Tree appears healthy. | Retain. |
| 4 | Scots Pine | 34 | 2 | 2 | 2 | 2 | 17 | 4.1 | M | B | Tree appears healthy. | Retain. |
| 5 | Birch | 15 | 1 | 1 | 1 | 1 | 7 | 1.8 | SM | B | Suppressed tree, appears healthy. | Retain. |
| 6 | Scots Pine | 32 | 2 | 2 | 4 | 2 | 15 | 3.8 | M | B | 1s canopy east, appears healthy. | Retain. |
| 7 | Scots Pine | 36 | 2 | 4 | 2 | 2 | 18 | 4.3 | M | B | Canopy mainly one-sided south. Tree appears healthy. | Retain. |
| 8 | Scots Pine | 38 | 4 | 3 | 4 | 3 | 17 | 4.6 | M | B | Tree appears healthy. | Retain. |
| 9 | Scots Pine | 25 | 2 | 1 | 1 | 1 | 18 | 3.0 | M | C | Tall, thin tree with a suppressed canopy. | Retain. |
| 10 | Scots Pine | 30 | 2 | 2 | 2 | 2 | 18 | 3.6 | M | B | Tree appears healthy. | Retain. |
| 11 | Scots Pine | 28 | 4 | 2 | 2 | 3 | 17 | 3.4 | M | B | Tree appears healthy. | Retain. |
| 12 | Scots Pine | 39 | 5 | 2 | 3 | 3 | 17 | 4.7 | M | B | Tree appears healthy. | Retain. |
| 13 | Scots Pine | 33 | 2 | 4 | 2 | 2 | 18 | 4.0 | M | B | Canopy mainly one-sided to south. Tree appears healthy. | Retain. |
| 14 | Scots Pine | 25 | 2 | 2 | 3 | 2 | 17 | 3.0 | M | B | Tree appears healthy. | Retain. |
| 15 | Scots Pine | 29 | 2 | 2 | 2 | 2 | 16 | 3.5 | M | B | Tree appears healthy. | Retain. |
| 16 | Scots Pine | 60 | 2 | 2 | 2 | 2 | 17 | 7.2 | M | B | Tree appears healthy. | Retain. |
| 17 | Scots Pine | 35 | 2 | 2 | 3 | 2 | 18 | 4.2 | M | B | Tree appears healthy. | Retain. |
| 18 | Scots Pine | 27 | 3 | 1 | 2 | 1 | 16 | 3.2 | M | B | Tree appears healthy. | Retain. |



| No | Species | Dia at 1.5m (cm) | Canopy Radius (m) | | | | Height (m) | RPA (m) | Age | Class | Description | Action |
|----|------------|------------------|-------------------|---|---|---|------------|---------|-----|-------|--|---------|
| | | | N | S | E | W | | | | | | |
| 19 | Scots Pine | 25 | 2 | 2 | 2 | 2 | 17 | 3.0 | M | B | Tree appears healthy. | Retain. |
| 20 | Scots Pine | 33 | 3 | 3 | 3 | 3 | 17 | 4.0 | M | B | Tree appears healthy. | Retain. |
| 21 | Scots Pine | 36 | 2 | 2 | 4 | 3 | 18 | 4.3 | M | B | Tree appears healthy. | Retain. |
| 22 | Scots Pine | 27 | 4 | 1 | 5 | 2 | 17 | 3.2 | M | C | Canopy mainly one-sided to north and east. Deadwood and snags apparent. | Retain. |
| 23 | Scots Pine | 33 | 1 | 1 | 2 | 1 | 16 | 4.0 | M | B | Bark damage from machinery at base, 1 m, and 2 m on south side. | Retain. |
| 24 | Scots Pine | 35 | 2 | 4 | 3 | 3 | 17 | 4.2 | M | B | Deadwood apparent on north side but tree appears healthy. | Retain. |
| 25 | Scots Pine | 29 | 2 | 2 | 2 | 2 | 17 | 3.5 | M | C | Tree leans east, appears healthy. | Retain. |
| 26 | Scots Pine | 39 | 3 | 3 | 5 | 2 | 17 | 4.7 | M | C | Tree has a slight lean northeast. Deadwood and snags apparent. | Retain. |
| 27 | Scots Pine | 32 | 2 | 2 | 3 | 2 | 17 | 3.8 | M | B | Tree appears healthy. | Retain. |
| 28 | Scots Pine | 31 | 4 | 4 | 4 | 4 | 16 | 3.7 | M | B | Tree is twin-stemmed from 2.5 m, appears healthy. | Retain. |
| 29 | Scots Pine | 27 | 2 | 3 | 3 | 2 | 17 | 3.2 | M | B | Tree appears healthy. | Retain. |
| 30 | Scots Pine | 42 | 3 | 5 | 4 | 4 | 17 | 5.0 | M | B | Tree appears healthy. | Retain. |
| 31 | Scots Pine | 42 | 3 | 5 | 4 | 3 | 17 | 5.0 | M | C | Tree has substantial bark damage from machinery at base. Some deadwood and snags apparent. | Retain. |
| 32 | Scots Pine | 39 | 5 | 5 | 5 | 4 | 18 | 4.7 | M | B | Some deadwood and snags apparent but tree appears healthy. | Retain. |
| 33 | Scots Pine | 29 | 2 | 2 | 2 | 2 | 17 | 3.5 | M | B | Tall, thin tree. Base buried in soil pile. | Retain. |
| 34 | Scots Pine | 33 | 2 | 3 | 2 | 2 | 17 | 4.0 | M | B | Tree has a slight lean east but appears healthy. | Retain. |
| 35 | Scots Pine | 34 | 3 | 1 | 3 | 3 | 18 | 4.1 | M | B | Tree appears healthy. | Retain. |
| 36 | Scots Pine | 33 | 3 | 4 | 2 | 2 | 17 | 4.0 | M | B | Tree is twin-stemmed from 7 m, appears healthy. | Retain. |
| 37 | Scots Pine | 37 | 4 | 2 | 3 | 3 | 17 | 4.4 | M | B | Tree appears healthy. | Retain. |
| 38 | Scots Pine | 35 | 3 | 2 | 3 | 2 | 17 | 4.2 | M | B | Tree appears healthy. | Retain. |



| No | Species | Dia at 1.5m (cm) | Canopy Radius (m) | | | | Height (m) | RPA (m) | Age | Class | Description | Action |
|----|------------|------------------|-------------------|---|---|---|------------|---------|-----|-------|---|-----------------------|
| | | | N | S | E | W | | | | | | |
| 39 | Scots Pine | 28 | 4 | 2 | 3 | 2 | 17 | 3.4 | M | B | Tree appears healthy. | Retain. |
| 40 | Scots Pine | 29, 11 | 3 | 3 | 3 | 3 | 17 | 3.7 | M | B | Tree is twin-stemmed from base. Small north limb has died. Base buried in soil pile. | Retain. |
| 41 | Scots Pine | 32 | 1 | 3 | 3 | 2 | 17 | 3.8 | M | B | Tree is twin-stemmed from 6 m. Tree appears healthy. | Retain. |
| 42 | Scots Pine | 40 | 5 | 3 | 6 | 2 | 17 | 4.8 | M | B | Canopy mainly one-sided to north and east, appears healthy. | Retain. |
| 43 | Scots Pine | 39 | 4 | 4 | 3 | 5 | 17 | 4.7 | M | B | Tree appears healthy. | Retain. |
| 44 | Scots Pine | 27 | 2 | 3 | 2 | 2 | 16 | 3.2 | M | B | Tall, thin tree, leans southeast, appears healthy. | Retain. |
| 45 | Scots Pine | 42 | 5 | 1 | 4 | 4 | 18 | 5.0 | M | B | Canopy mainly one-sided to north, appears healthy. | Retain. |
| 46 | Scots Pine | 34 | 2 | 3 | 3 | 3 | 17 | 4.1 | M | B | Tree appears healthy. | Retain. |
| 47 | Scots Pine | 26 | 2 | 2 | 2 | 2 | 17 | 3.1 | M | B | Base buried by soil pile, appears healthy. | Retain. |
| 48 | Scots Pine | 36 | 4 | 4 | 4 | 4 | 15 | 4.3 | M | B | Tree appears healthy. | Retain. |
| 49 | Scots Pine | 28 | 2 | 3 | 5 | 1 | 17 | 3.4 | M | C | Canopy suppressed to west. Deadwood and snags apparent. | Retain. |
| 50 | Scots Pine | 31 | 2 | 2 | 2 | 2 | 15 | 3.7 | M | C | Tree leans northwest. Base buried in soil pile. | Fell for development. |
| 51 | Scots Pine | 40 | 3 | 2 | 5 | 2 | 17 | 4.8 | M | B | Tree appears healthy. | Fell for development. |
| 52 | Scots Pine | 47 | 3 | 4 | 5 | 3 | 18 | 5.6 | M | B | Canopy suppressed to north and east. Some old bark damage on east side at 1.8 m, appears healthy. | Fell for development. |
| 53 | Larch | 39 | 2 | 5 | 5 | 3 | 22 | 4.7 | M | B | Tree has a slight lean northeast. Canopy mainly one-sided to east, appears healthy. | Fell for development. |
| 54 | Scots Pine | 37 | 4 | 5 | 4 | 4 | 19 | 4.4 | M | B | Tree leans northeast, appears healthy. | Fell for development. |
| 55 | Scots Pine | 33 | 4 | 3 | 3 | 0 | 16 | 4.0 | M | B | Tree has bark damage from machinery on east and south sides at 2 m and 1.7 m respectively. Soil piled at base. Canopy suppressed to west. | Fell for development. |
| 56 | Scots Pine | 38 | 4 | 5 | 2 | 2 | 17 | 4.6 | M | B | Tree has some bark damage on west side at 1 m, appears healthy. | Fell for development. |



| No | Species | Dia at 1.5m (cm) | Canopy Radius (m) | | | | Height (m) | RPA (m) | Age | Class | Description | Action |
|----|------------|------------------|-------------------|---|---|---|------------|---------|-----|-------|---|-----------------------|
| | | | N | S | E | W | | | | | | |
| 57 | Larch | 37 | 3 | 3 | 4 | 2 | 14 | 4.4 | M | B | Tree has a slight lean northeast, appears healthy. | Retain. |
| 58 | Scots Pine | 39 | 1 | 4 | 2 | 2 | 11 | 4.7 | M | C | Canopy mainly one-sided to south. Various small cavities on east side. | Retain. |
| 59 | Scots Pine | 42 | 5 | 4 | 3 | 3 | 15 | 5.0 | M | B | Tree has a slight lean northeast, appears healthy. | Retain. |
| 60 | Scots Pine | 45 | 4 | 3 | 3 | 3 | 16 | 5.4 | M | B | Tree has a slight lean northeast but appears healthy. | Fell for development. |
| 61 | Scots Pine | 52 | 3 | 4 | 5 | 6 | 18 | 6.2 | M | C | Tree has substantial bark damage from machinery from base to 2.5 m on south side. | Fell for development. |
| 62 | Scots Pine | 28 | 3 | 3 | 3 | 2 | 17 | 3.4 | M | B | Tree appears healthy. | Retain. |
| 63 | Scots Pine | 30 | 4 | 4 | 5 | 4 | 19 | 3.6 | M | B | Tree appears healthy. | Retain. |
| 64 | Larch | 35 | 4 | 3 | 4 | 4 | 21 | 4.2 | M | B | Tree appears healthy. | Retain. |
| 65 | Scots Pine | 55 | 6 | 4 | 5 | 5 | 19 | 6.6 | M | B | Tree has slight bark damage on west side, appears healthy. | Retain. |
| 66 | Scots Pine | 35 | 4 | 4 | 4 | 4 | 19 | 4.2 | M | B | Tree appears healthy. | Retain. |
| 67 | Scots Pine | 36 | 4 | 4 | 4 | 4 | 18 | 4.3 | M | B | Tree appears healthy. | Retain. |
| 68 | Scots Pine | 29 | 2 | 4 | 4 | 1 | 18 | 3.5 | M | B | Canopy suppressed to west but tree appears healthy. | Retain. |
| 69 | Scots Pine | 34 | 2 | 4 | 5 | 2 | 18 | 4.1 | M | B | Tree appears healthy. | Retain. |
| 70 | Scots Pine | 41 | 3 | 4 | 5 | 2 | 17 | 4.9 | M | B | Canopy suppressed to west. Tree appears healthy. | Retain. |
| 71 | Scots Pine | 33 | 4 | 1 | 3 | 1 | 18 | 4.0 | M | C | Tall, thin tree with a mainly one-sided canopy northeast. | Retain. |



Appendix B: Plan of Badger Setts in Stratton Woods

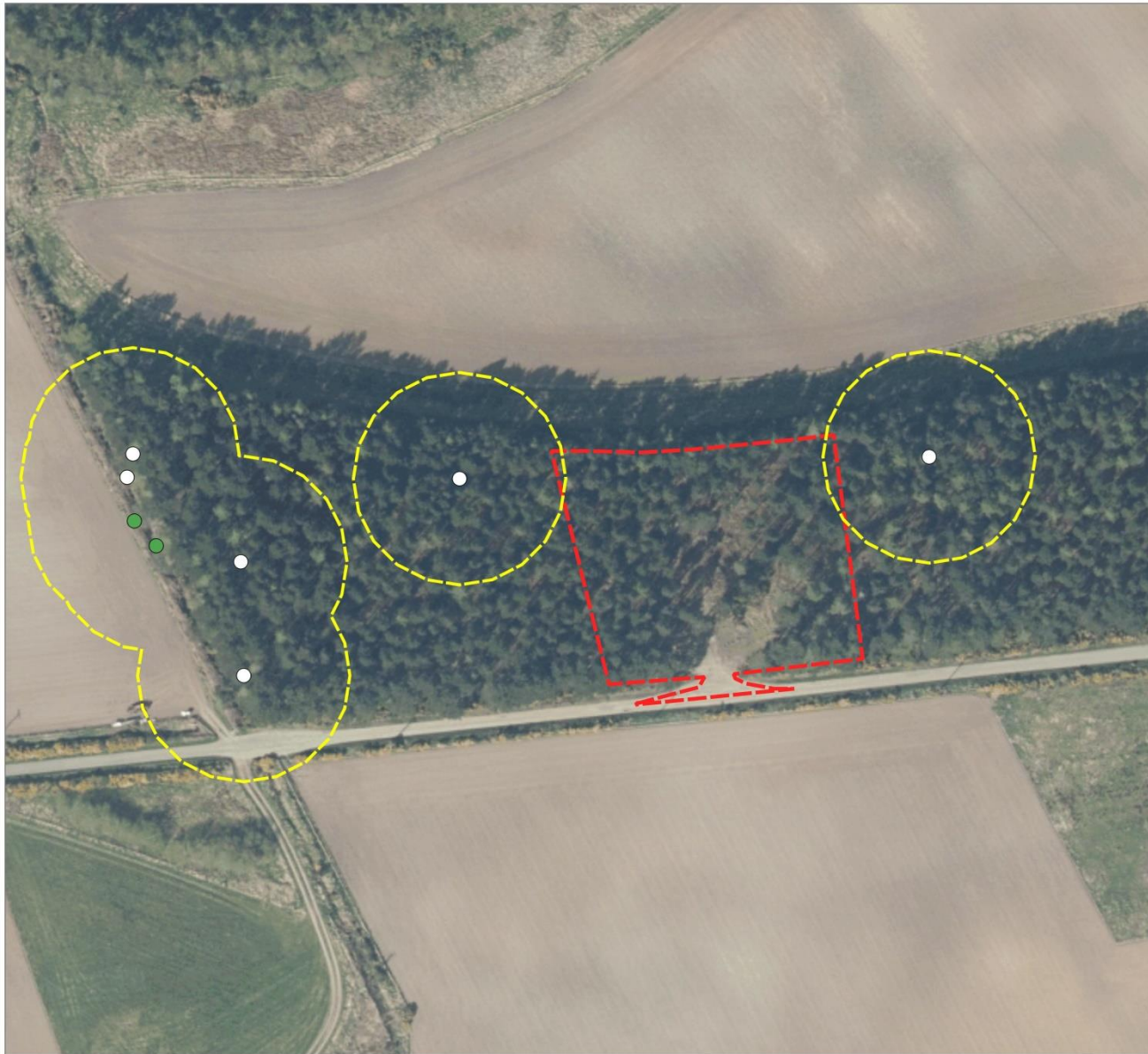

Legend

- Disused badger sett
- Active badger sett
- 30 m exclusion zone

Note: The original of this drawing was produced in colour – a monochrome copy should not be relied upon.

| | |
|--|-----------------|
| Site at Phase 1 Habitat Map | |
| Client | Samantha Hancox |
| Drawing No: | SWF-2202-BS |
| Issue Date | 07/02/2022 |
| Drawn by | AM |
| Checked by: | NA |
| Revision date: | |
| Scale: | 1:1,000 @ A3 |
|  astell associates <small>arboricultural, environmental and landscape consultants</small> | |
| <small>10 Polston Road, Maryculter, Aberdeen, AB12 5GY tel: 01224 734372 email: info@astellassociates.co.uk</small> | |



Appendix C: Tree Quality Assessment Chart - Adapted from BS: 5837 2012

| Table 1: Cascade chart for tree quality assessment | | | | |
|--|--|--|---|------------------------|
| Category and definition | Criteria (including subcategories where appropriate) | | | Identification on plan |
| <p>Category U Trees which cannot be retained long-term (for longer than 10 years)</p> | <ul style="list-style-type: none"> Trees that have a serious structural defect which puts them at risk of collapse, including those that will become unviable after removal of other trees Trees that are dead or dying Trees infected with pathogens which could affect the health and/or safety of nearby trees, or very low-quality trees which suppress trees of better quality <p><i>NOTE Category U trees can have existing or potential conservation value which might be desirable to preserve.</i></p> | | | DARK RED |
| TREES TO BE CONSIDERED FOR RETENTION | | | | |
| | 1 Mainly arboricultural values | 2 Mainly landscape values | 3 Mainly cultural values, including conservation | |
| <p>Category A Trees of high quality and value: in good condition; able to persist for long (a minimum of 40 years).</p> | Trees that are particularly good examples of their species, especially if rare or unusual; or those that are essential components of groups (e.g. the dominant and/or principal trees within an avenue). | Trees, groups or woodlands of particular visual importance. | Trees, groups or woodlands of significant conservation, historical, or other value (e.g. veteran trees) | LIGHT GREEN |
| <p>Category B Trees of moderate quality with an estimated remaining life expectancy of at least 20 years</p> | Trees downgraded from category A because of impaired condition (e.g. presence of minor defects, including unsympathetic past management or storm damage). | Collections of trees (in groups or woodlands) with a higher rating than they would have as individuals. | Trees with some conservation or other cultural value | MID BLUE |
| <p>Category C Trees of low quality with an estimated remaining life expectancy of at least 10 years, or young trees with a stem diameter below 150 mm</p> | Unremarkable trees of very limited merit or such impaired condition that they do not qualify in higher categories | Trees present in groups or woodlands, without significantly greater collective landscape value; and/or trees offering low or only temporary landscape benefits | Trees with no conservation or other cultural value | GREY |



Appendix D: Tree Life Stages from BS: 5837

| | |
|----|--------------|
| Y | Young |
| SM | Semi-mature |
| EM | Early-mature |
| M | Mature |
| OM | Over-mature |
| V | Veteran |

Appendix E: Drawings

| | |
|--------------|---|
| SWF-2202-AA: | Arboricultural Assessment Plan showing existing site layout, positions of all trees, root protection areas, canopy spread and arboricultural assessment. |
| SWF-2202-TP: | Tree Management and Root Protection Areas Plan showing the proposed development, indicating trees to be felled or retained, root protection areas, canopy spread and tree protection fencing or other tree/root protection measures. |

Appendix F: Legislation, Guidance and References

- BS5837:2012 - Trees in relation to design, demolition and construction – Recommendations (BSI, 2012),
- Arboricultural Association Guidance Note 7 Tree Surveys: A Guide to Good Practice Aberdeen Local
- Development Plan Supplementary Guidance: Trees and Woodlands (2017)
- Town and Country Planning (Scotland) Act 1997 (as amended)
- Health & Safety at Work Act 1974
- Construction (Design & Management) Regulations 2015
- Scottish Government Policy on the Control of Woodland Removal



Appendix G: Professional Qualifications

Nigel Astell has been involved in arboriculture for over 40 years. He holds degrees in Botany and Zoology and is a member of the Arboricultural Association and The Chartered Institute of Environmental and Ecological Management.

Aaron Meijer has a BSc in Applied Biology and has worked in the ecology field for several years, both in the UK and in the Netherlands.

Appendix H: Contact Details

Client: Samantha Hancox

Architect: John Wink Design
Midtown of Foudland,
Glens of Foudland,
Huntly,
Aberdeenshire,
AB54 6AR

Environmental Consultant:
Astell Associates
10 Polston Road
Maryculter
Aberdeen
Ab12 5GY
Tel 01224 734372
email: info@astellassociates.co.uk



Appendix I: Protective Barrier & Ground Protection - BS: 5837 - 2012

Figure 2 which is taken from BS: 5837 2012 “Trees in Relation to Design, Demolition & Construction – Recommendations” illustrate the systems to be employed for ensuring an adequate Construction Exclusion Zone about retained trees. Refer to BS: 5837 2012 for more details.

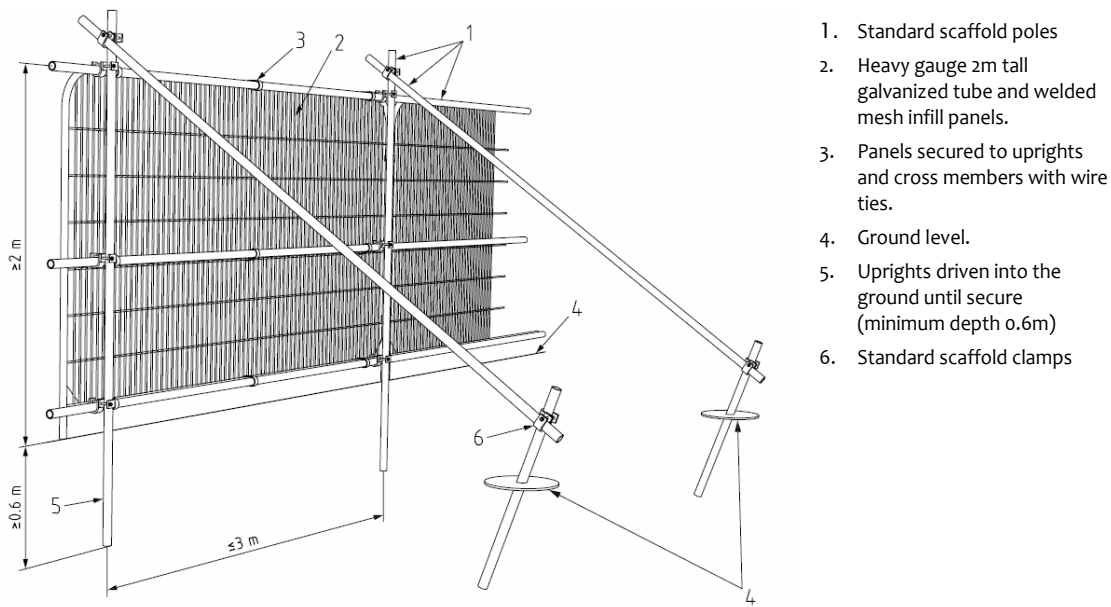

Figure 2: Protective Barrier

Keep Out

Tree Protection Area

Construction Exclusion Zone

| | |
|--|---|
| No entry to Personnel No dumping of Waste | No Construction Vehicles No Storage of Materials |
|--|---|

All-weather notices should be attached to the barrier with words such as: “CONSTRUCTION EXCLUSION ZONE – NO ACCESS”. An example is shown above.



Developer Obligations & Affordable Housing: ASSESSMENT REPORT

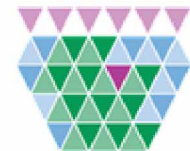

MORAY
council

Date: 08/11/2021

Reference: 21/01664/PPP

Description: Erect dwellinghouse on Site At Stratton Wood, Fochabers

Applicant: Mr & Mrs S Hancox

Agent: John Wink Design

This assessment has been carried out by Moray Council. For developer obligations, the assessment is carried out in relation to policy PP3 Infrastructure and Services of the adopted Moray Local Development Plan 2020 (MLDP2020) and Supplementary Guidance (SG) on Developer Obligations which was adopted on 30 September 2020. And, for affordable housing, the assessment is carried out in relation to policy DP2 Housing of the MLDP2020. Affordable housing is a policy requirement not a developer obligation however for ease of reference the Affordable Housing contribution is included within this assessment.

The MLDP2020 can be found at www.moray.gov.uk/MLDP2020 and the Developer Obligations SG can be found at <http://www.moray.gov.uk/downloads/file134184.pdf>

Summary of Obligations

| | |
|--|------------|
| Primary Education | Nil |
| Secondary Education | Nil |
| Transport (<i>Contribution towards Demand Responsive Transport-dial-a-bus</i>) | ██████████ |
| Healthcare (<i>Contribution towards New Build Health Centre in Fochabers</i>) | ██████████ |
| Sports and Recreation | Nil |
| Total Developer Obligations | ██████████ |
| | ██████████ |
| Affordable Housing | ██████████ |
| TOTAL | ██████████ |

Breakdown of Calculation

Proposals for developer obligations are assessed on the basis of Standard Residential Unit Equivalents (SRUE) which is a 3-bedroomed residential unit. This application is considered to comprise of the following:

3 bed = 1 SRUE

This assessment is therefore based on 1 SRUE.



Moray Council **DEVELOPER OBLIGATIONS**

INFRASTRUCTURE

Education

Primary Education

The pupils generated by this development are zoned to Lhanbryde Primary School. The school is currently operating at 56% physical capacity and the additional pupil as a result of this development can be accommodated. As a result, no mitigation is necessary in this instance.

Contribution towards Primary Education = Nil

Secondary Education

The pupils generated by this development are zoned to Milnes High School. The school is currently operating at 63% capacity and the additional pupil as a result of this development can be accommodated. As a result, no mitigation is necessary in this instance.

Contribution towards Secondary Education = Nil

Transport

The Moray Council Transportation Services has confirmed that a contribution towards the Council's demand responsive transport service is required to mitigate the impact, in terms of increased usage, on this service given the proposed development is located within a rural area with no access to bus services. In accord with the Moray Council's Supplementary Guidance on Developer Obligations, a contribution of [REDACTED] per SRUE is sought. Therefore:

[REDACTED]

Contributions towards Transport = [REDACTED]

Healthcare

Healthcare Facilities include General Medical Services (GMS), community pharmacies and dental practices. Scottish Health Planning Notes provide national guidance on standards and specification for healthcare facilities. The recommended number of patients is 1500 per General Practitioner (GP) and floorspace requirement per GP is 271m².

Healthcare infrastructure requirements have been calculated with NHS Grampian on the basis of national standards and specifications for healthcare facilities and estimating the likely number of new patients generated by the development (based on the average household size of 2.17 persons -Census 2011).

Fochabers Medical Practice is the nearest GP Practice within which healthcare facilities can be accessed by the proposed development. NHS Grampian has confirmed that Fochabers Medical Practice is working well beyond design capacity with no room for expansion on existing site and contributions are sought towards a New Build Health Centre.

Contributions are calculated based on a proportional contribution of [REDACTED] per SRUE.

[REDACTED]

Contribution towards Healthcare= [REDACTED]

Sports and Recreational Facilities

Sports and Recreation Facilities

Existing sports provision within Fochabers is considered to be adequate to serve the needs of the residents anticipated to be generated



by this development. Therefore, in this instance, no contribution will be required.

Contribution for Sports and Recreation Facilities = Nil

AFFORDABLE HOUSING

The average market value of a serviced plot for 1 Affordable Unit within the Elgin local Housing Market Area is [REDACTED]

Contributions are based on 25% of the total number of units proposed in the application:

[REDACTED]

Therefore, the total contribution towards affordable housing is:

1 proposed unit = [REDACTED]

Affordable housing is a policy requirement not a developer obligation and will not be subject to negotiation.



TERMS OF ASSESSMENT

This assessment report is valid for a period of 6 months from the date of issue.

Please note that any subsequent planning applications for this site may require a re-assessment to be undertaken on the basis of the policies and rates pertaining at that time.

PAYMENT OF CONTRIBUTIONS

Remittance of financial obligations can be undertaken either through the provision of an upfront payment or by entering into a Section 75 agreement. The provision of an upfront payment will allow a planning consent to be issued promptly. However, where the amount of developer contributions are such that an upfront payment may be considered prohibitive a Section 75 will likely be required. The payment of contributions may be tied into the completion of houses through a Section 75 Agreement or equivalent, to facilitate the delivery of development. Please note that Applicants are liable for both the legal costs of their own Legal Agent fees and Council's legal fees and outlays in the preparation of the document. These costs should be taken into account when considering the options.

INDEXATION

Developer obligations towards Moray Council infrastructure are index linked to the General Building Cost Price Index (BCPI) as published by the Building Cost Information Service (BCIS) of the Royal Institute of Chartered Surveyors (RICS) from Q3, 2017 and obligations towards NHS Grampian infrastructure are index linked to All in Tender

Price Index (TPI) as published by the Royal Institute of Chartered Surveyors (RICS) from Q2, 2017.



From: Teresa Ruggeri <Teresa.Ruggeri@moray.gov.uk>

Sent: 09 Nov 2021 10:11:34

To: DMSMyEmail@moray.gov.uk

Cc:

Subject: FW: 21/01664/PPP Erect dwellinghouse on Site At Stratton Wood, Fochabers

Attachments: 21-01664-APP Erect dwellinghouse on Site At Stratton Wood, Fochabers.pdf

Hi,

Please find attached the developer obligations assessment that has been undertaken for the above planning application. A copy of the report has been sent to the applicant.

Thanks,
Rebecca

Rebecca Morrison | Infrastructure Growth/Obligations Officer (Strategic Planning and Development) | Economic Growth and Development

rebecca.morrison@moray.gov.uk | [website](#) | [facebook](#) | [twitter](#) | [instagram](#) | [news](#)

MORAY
council

Consultation Request Notification – Development Plans

| | |
|--|---|
| Planning Authority Name | Moray Council |
| Response Date | 8th December 2021 |
| Planning Authority Reference | 21/01664/PPP |
| Nature of Proposal (Description) | Erect dwellinghouse on |
| Site | Site At Stratton Wood Fochabers Moray |
| Site Postcode | N/A |
| Site Gazetteer UPRN | 000133074608 |
| Proposal Location Easting | 329958 |
| Proposal Location Northing | 858189 |
| Area of application site (M²) | 5640 |
| Additional Comments | Agent states no trees to be removed tree survey requested as believe development may impact on trees |
| Development Hierarchy Level | LOCAL |
| Supporting Documentation URL | https://publicaccess.moray.gov.uk/eplanning/centralDistribution.do?caseType=Application&keyVal=R17O4DBGIX900 |
| Previous Application | |
| Date of Consultation | 24th November 2021 |
| Is this a re-consultation of an existing application? | No |
| Applicant Name | Mr & Mrs S Hancox |
| Applicant Organisation Name | |
| Applicant Address | Per Agent |
| Agent Name | John Wink Design |
| Agent Organisation Name | |
| Agent Address | Midtown Of Foudland Glens Of Foudland Huntly Aberdeenshire AB54 6AR |
| Agent Phone Number | |
| Agent Email Address | N/A |
| Case Officer | Fiona Olsen |
| Case Officer Phone number | 01343 563189 |
| Case Officer email address | fiona.olsen@moray.gov.uk |
| PA Response To | consultation.planning@moray.gov.uk |

NOTE:

If you do not respond by the response date, it will be assumed that you have no comment to make.

The statutory period allowed for a consultation response is 14 days. Due to scheduling pressures if a definitive response is not received within 21 days this may well cause the two month determination period to be exceeded.

Data Protection - Moray Council is the data controller for this process. Information collected about you on this form will be used to process your Planning Application, and the Council has a duty to process your information fairly. Information we hold must be accurate, up to date, is kept only for as long as is necessary and is otherwise shared only where we are legally obliged to do so. You have a legal right to obtain details of the information that we hold about you.

For full terms please visit http://www.moray.gov.uk/moray_standard/page_121513.html

For full Data Protection policy, information and rights please see http://www.moray.gov.uk/moray_standard/page_119859.html

You can contact our Data Protection Officer at info@moray.gov.uk or 01343 562633 for more information.

Please respond using the attached form:-

PLEASE COMPLETE AND RETURN WITHIN 48 HOURS
to consultation.planning@moray.gov.uk

MORAY COUNCIL PLANNING CONSULTATION RESPONSE

From: Development Plans

Planning Application Ref. No: 21/01664/PPP

Erect dwellinghouse on Site At Stratton Wood Fochabers Moray for Mr & Mrs S Hancox

Ward: 04_17 Fochabers Lhanbryde

DETERMINATION - DEPARTURE FROM DEVELOPMENT PLAN

(For Structure/Local Plan Comment)

| | | Page No | Policy No(s) | Yes | No |
|---|--|---------|---|-------------|----|
| 1 | Departure from Moray Local Development Plan 2015 | | EP7 Forestry, Woodland and Trees DP4 Rural Housing DP1 Development Principles | X X X | |
| 2 | Further Discussion Required | | | | |

REASONING FOR THIS DECISION:

POLICY COMMENTS

The application is for planning permission in principle for a single dwellinghouse. The house is located within an area of woodland identified as woodland in the National Forestry Inventory Scotland.

Policy EP7 Forestry, Woodlands and Trees

Policy EP7 c) is informed by and supports the Scottish Government's control of woodland removal policy. Although not located in ancient woodland, the policy states that other woodland development which involves permanent woodland removal will only be permitted where it would achieve significant and clearly defined additional public benefits (excluding housing). The Additional Planning Policy Guidance further clarifies this position and states that Moray Council does not include housing within the definition of public benefits, sustainable economic growth, or rural/community development.

In this instance the proposal for a private residential house does not meet the policy criteria as being an acceptable use to justify the removal of woodland and is contrary to policy.

The applicant has stated that the application site is located within a clearing within the woodland and will not result in the loss of a significant number of trees. The supporting information provided also states that the applicant has a felling licence for the area. However, regardless of the house being potentially located in a clearing with minimal tree loss and having a felling licence, in land use terms the land is identified as woodland where there is a strong policy support in favour of retention making the principle of a change of use to residential contrary to those aims.

As such the application for a residential house would result in the unacceptable change of use and permanent loss of land identified as woodland in the National Forestry Inventory Scotland which is contrary to policy EP7.

DP4 Rural Housing, DP 1 Development Principles

The application site is located within an area of intermediate pressure and therefore any proposal must comply with the siting and design criteria set out in the policy. In terms of this application, the siting of the proposed house has been deemed to be unacceptable as it would result in the permanent loss of woodland which is contrary to Policy EP7.

In losing this woodland the proposal would fail to comply with part 3 of the policy which states that the clear felling of woodland to create plots will not be permitted. As stated above, regardless of the number of trees that may or may not be getting felled as part of the proposal, in land use terms the whole site is identified as woodland where there is strong policy support at a national and local level for it to be retained. Therefore in failing to comply with Policy EP7 the proposal fails to comply with the siting criteria of DP4.

Update

Following on from the previous response (16/12/21) the applicant has provided a tree report and justification for the proposed tree removal. The applicant's justification is that the removal of trees is required 'to allow for sufficient access to the proposed development and for service ducts to be routed from the public road to the house'. While the applicant

Consultation Request Notification

| | |
|--|---|
| Planning Authority Name | Moray Council |
| Response Date | 16th November 2021 |
| Planning Authority Reference | 21/01664/PPP |
| Nature of Proposal (Description) | Erect dwellinghouse on |
| Site | Site At Stratton Wood Fochabers Moray |
| Site Postcode | N/A |
| Site Gazetteer UPRN | 000133074608 |
| Proposal Location Easting | 329958 |
| Proposal Location Northing | 858189 |
| Area of application site (M²) | 5640 |
| Additional Comment | |
| Development Hierarchy Level | LOCAL |
| Supporting Documentation URL | https://publicaccess.moray.gov.uk/eplanning/centralDistribution.do?caseType=Application&keyVal=R17O4DBGIX900 |
| Previous Application | |
| Date of Consultation | 2nd November 2021 |
| Is this a re-consultation of an existing application? | No |
| Applicant Name | Mr & Mrs S Hancox |
| Applicant Organisation Name | |
| Applicant Address | Per Agent |
| Agent Name | John Wink Design |
| Agent Organisation Name | |
| Agent Address | Midtown Of Foudland Glens Of Foudland Huntly Aberdeenshire AB54 6AR |
| Agent Phone Number | |
| Agent Email Address | N/A |
| Case Officer | Fiona Olsen |
| Case Officer Phone number | 01343 563189 |
| Case Officer email address | fiona.olsen@moray.gov.uk |
| PA Response To | consultation.planning@moray.gov.uk |

NOTE:

If you do not respond by the response date, it will be assumed that you have no comment to make.

The statutory period allowed for a consultation response is 14 days. Due to scheduling pressures if a definitive response is not received within 21 days this may well cause the

two month determination period to be exceeded.

Data Protection - Moray Council is the data controller for this process. Information collected about you on this form will be used to process your Planning Application, and the Council has a duty to process your information fairly. Information we hold must be accurate, up to date, is kept only for as long as is necessary and is otherwise shared only where we are legally obliged to do so. You have a legal right to obtain details of the information that we hold about you.

For full terms please visit http://www.moray.gov.uk/moray_standard/page_121513.html

For full Data Protection policy, information and rights please see http://www.moray.gov.uk/moray_standard/page_119859.html

You can contact our Data Protection Officer at info@moray.gov.uk or 01343 562633 for more information.

Please respond using the attached form:-

MORAY COUNCIL

PLANNING CONSULTATION RESPONSE

From: Transportation Manager

Planning Application Ref. No: 21/01664/PPP

Erect dwellinghouse on Site At Stratton Wood Fochabers Moray for Mr & Mrs S Hancox

I have the following comments to make on the application:-

- | | Please |
|---|-------------------------------------|
| (a) I OBJECT to the application for the reason(s) as stated below | <input type="checkbox"/> |
| (b) I have NO OBJECTIONS to the application and have no condition(s) and/or comment(s) to make on the proposal | <input type="checkbox"/> |
| (c) I have NO OBJECTIONS to the application subject to condition(s) and/or comment(s) about the proposal as set out below | <input checked="" type="checkbox"/> |
| (d) Further information is required in order to consider the application as set out below | <input type="checkbox"/> |

Condition(s)

1. No development shall commence until:

- (i) a detailed drawing (scale 1:500 or 1:1000 which shall also include details to demonstrate control of the land) showing the visibility splay 2.4 metres by 160 metres in both directions, with all boundaries set back to a position behind the required visibility splay, and a schedule of maintenance for the splay area has been submitted to and approved in writing by the Council, as Planning Authority in consultation with the Roads Authority; and
- (ii) thereafter the visibility splay shall be provided in accordance with the approved drawing prior to any works commencing (except for those works associated with the provision of the visibility splay); and
- (iii) thereafter the visibility splay shall be maintained at all times free from any obstruction exceeding 0.6 metres above the level of the carriageway in accordance with the agreed schedule of maintenance.

Reason: To enable drivers of vehicles leaving the site to have a clear view over a length of road sufficient to allow safe exit, in the interests of road safety for the proposed development and other road users through the provision of details currently lacking.

2. No development works shall commence on the dwelling house until a detailed drawing (scale 1:200) has been submitted to and approved in writing by the Council, as Planning Authority in consultation with the Roads Authority confirming the provision of, or location where a future Electric Vehicle (EV) charging unit is to be connected to an appropriate electricity supply, including details (written proposals and/ or plans) to confirm the provision of the necessary cabling, ducting, and consumer units capable of supporting the

future charging unit; and thereafter the EV charging infrastructure shall be provided in accordance with the approved drawing and details prior to the first occupation of the dwelling house.

Reason: In the interests of an acceptable form of development and the provision of infrastructure to support the use of low carbon transport, through the provision of details currently lacking.

3. No development shall commence until a detailed drawing (scale 1:500) showing the location and design of a passing place on the section of the U20E Barentinan Road or the U21E Millhill Road (to the Moray Council standards and specification), has been submitted to and approved in writing by the Council, as Planning Authority in consultation with the Roads Authority; and thereafter the passing place shall be constructed in accordance with the approved drawing prior to any development works commencing (except for those works associated with the provision of the passing place).

Reason: To enable drivers of vehicles to have adequate forward visibility to see approaching traffic and for two vehicles to safely pass each other ensuring the safety and free flow of traffic on the public road

4. Prior to the first occupation of the dwelling house, the first 5m of the access track, measured from the edge of the public carriageway, shall be constructed to the Moray Council specification and surfaced with bituminous macadam. The width of the vehicular access shall be minimum 3.5 metres, and have a maximum gradient of 1:20 measured for the first 5.0m from the edge of the public carriageway.

Reason: To ensure acceptable infrastructure at the development access.

5. Notwithstanding the submitted details prior to the first occupation of the dwelling house, an access lay-by 8.0m long by 2.5m wide with 30 degrees splayed ends shall be provided at the edge of the public road. The vehicular access should lead off the lay-by. The lay-by must be constructed in accordance with the Moray Council specification and surfaced with bituminous macadam.

Reason: To enable visiting service vehicles to park clear of the public road in the interests of road safety.

6. Any existing ditch, watercourse or drain under the site access shall be piped using a suitable diameter of pipe, agreed with the Roads Maintenance Manager (300mm minimum). The pipe shall be laid to a self-cleansing gradient and connected to an outfall.

Reason: To ensure the construction of an acceptable access in the interests of road safety and effective drainage infrastructure.

7. Parking provision shall be as follows:

- 2 spaces for a dwelling with two or three bedrooms; or
- 3 spaces for a dwelling with four bedrooms or more.

The car parking spaces shall be provided within the site prior to the occupation or completion of the dwelling house, whichever is the sooner. The parking spaces shall

thereafter be retained throughout the lifetime of the development, unless otherwise agreed in writing with the Council as Planning Authority.

Reason: To ensure the permanent availability of the level of parking necessary for residents/visitors/others in the interests of an acceptable development and road safety.

8. A turning area shall be provided within the curtilage of the site to enable vehicles to enter and exit in a forward gear.

Reason: To ensure the provision for vehicles to enter/exit in a forward gear in the interests of the safety and free flow of traffic on the public road

9. No water shall be permitted to drain or loose material be carried onto the public carriageway.

Reason: To ensure the safety and free flow of traffic on the public road and access to the site by minimising the road safety impact from extraneous material and surface water in the vicinity of the new access.

10. New boundary walls/fences shall be set back from the edge of the public carriageway at a minimum distance of 2.0m and to a position behind the required visibility splays.

Reason: To ensure acceptable development in the interests of road safety.

Further comment(s) to be passed to applicant

The formation of the required visibility splay will involve the removal of gorse and vegetation.

Planning consent does not carry with it the right to carry out works within the public road boundary.

The provision of Electric Vehicle (EV) chargers and/or associated infrastructure shall be provided in accordance with Moray Council guidelines. Cabling between charging units and parking spaces must not cross or obstruct the public road including footways. Infrastructure provided to enable EV charging must be retained for this purpose for the lifetime of the development unless otherwise agreed in writing by the Planning Authority. Guidance on Electric Vehicle (EV) Charging requirements can be found at: <http://www.moray.gov.uk/downloads/file134860.pdf>

Before starting any work on the existing public road the applicant is obliged to apply for a road opening permit in accordance with Section 56 of the Roads (Scotland) Act 1984. This includes any temporary access joining with the public road. Advice on these matters can be obtained by emailing roadspermits@moray.gov.uk

Before commencing development the applicant is obliged to apply for Construction Consent in accordance with Section 21 of the Roads (Scotland) Act 1984 for new roads (Passing Place). The applicant will be required to provide technical information, including drawings and drainage calculations. Advice on this matter can be obtained from the Moray Council web site or by emailing constructionconsent@moray.gov.uk

Public utility apparatus may be affected by this proposal. Contact the appropriate utility

service in respect of any necessary utility service alterations which have to be carried out at the expense of the developer.

No building materials/scaffolding/builder's skip shall obstruct the public road (including footpaths) without permission from the Roads Authority.

The applicant shall free and relieve the Roads Authority from any claims arising out of their operations on the road or extension to the road.

Contact: AG
email address: transport.develop@moray.gov.uk
Consultee: TRANSPORTATION

Date 18 November 2021

| | |
|---------------------------|---|
| Return response to | consultation.planning@moray.gov.uk |
|---------------------------|---|

Please note that information about the application including consultation responses and representations (whether in support or objection) received on the proposal will be published on the Council's website at <http://publicaccess.moray.gov.uk/eplanning/> (You can also use this site to track progress of the application and view details of any consultation responses and representations (whether in support or objection) received on the proposal). In order to comply with the Data Protection Act, personal information including signatures, personal telephone and email details will be removed prior to publication using "redaction" software to avoid (or mask) the display of such information. Where appropriate other "sensitive" information within documents will also be removed prior to publication online.

Consultee Comments for Planning Application 21/01664/PPP

Application Summary

Application Number: 21/01664/PPP

Address: Site At Stratton Wood Fochabers Moray

Proposal: Erect dwellinghouse on

Case Officer: Fiona Olsen

Consultee Details

Name: Mr CL Consultations

Address: Environmental Health, Council Offices, High Street Elgin, Moray IV30 1BX

Email: Not Available

On Behalf Of: Contaminated Land

Comments

Approved unconditionally

Consultee Comments for Planning Application 21/01664/PPP

Application Summary

Application Number: 21/01664/PPP

Address: Site At Stratton Wood Fochabers Moray

Proposal: Erect dwellinghouse on

Case Officer: Fiona Olsen

Consultee Details

Name: Mr EH Consultations

Address: Environmental Health, Council Offices, High Street Elgin, Moray IV30 1BX

Email: Not Available

On Behalf Of: Environmental Health C12

Comments

Approved unconditionally by Russell Anderson

MORAY COUNCIL

PLANNING CONSULTATION RESPONSE

From: Moray Flood Risk Management

Planning Application Ref. No: 21/01664/PPP

Erect dwellinghouse on Site at Stratton Wood Fochabers Moray for Mr & Mrs S Hancox

I have the following comments to make on the application:-

- | | Please |
|---|--------------------------------------|
| (a) I OBJECT to the application for the reason(s) as stated below | x <input type="checkbox"/> |
| (b) I have NO OBJECTIONS to the application and have no condition(s) and/or comment(s) to make on the proposal | <input checked="" type="checkbox"/> |
| (c) I have NO OBJECTIONS to the application subject to condition(s) and/or comment(s) about the proposal as set out below | <input type="checkbox"/> |
| (d) Further information is required in order to consider the application as set out below | <input type="checkbox"/> |

| | | |
|-----------------------|--|-----------------------------|
| Contact: | Javier Cruz | Date04/11/2021 |
| email address: | Javier.cruz@moray.gov.uk | Phone No |
| Consultee: | The Moray Council, Flood Risk Management | |

Wednesday, 03 November 2021



Local Planner
Development Services
Moray Council
Elgin
IV30 1BX

Development Operations
The Bridge
Buchanan Gate Business Park
Cumbernauld Road
Stepps
Glasgow
G33 6FB

Development Operations
Freephone Number - 0800 3890379
E-Mail - DevelopmentOperations@scottishwater.co.uk
www.scottishwater.co.uk



Dear Customer,

Site At Stratton Wood Fochabers, Fochabers, IV32 7LN
Planning Ref: 21/01664/PPP
Our Ref: DSCAS-0052099-M6N
Proposal: Erect dwellinghouse on

Please quote our reference in all future correspondence

Audit of Proposal

Scottish Water has no objection to this planning application; however, the applicant should be aware that this does not confirm that the proposed development can currently be serviced and would advise the following:

Water Capacity Assessment

Scottish Water has carried out a Capacity review and we can confirm the following:

- ▶ There is currently sufficient capacity in BADENTINAN Water Treatment Works to service your development. However, please note that further investigations may be required to be carried out once a formal application has been submitted to us.

Waste Water Capacity Assessment

- ▶ Unfortunately, according to our records there is no public Scottish Water, Waste Water infrastructure within the vicinity of this proposed development therefore we would advise applicant to investigate private treatment options.

Please Note

- ▶ The applicant should be aware that we are unable to reserve capacity at our water and/or waste water treatment works for their proposed development. Once a formal connection application is submitted to Scottish Water after full planning permission has been granted, we will review the availability of capacity at that time and advise the applicant accordingly.
-

Surface Water

For reasons of sustainability and to protect our customers from potential future sewer flooding, Scottish Water will not accept any surface water connections into our combined sewer system.

There may be limited exceptional circumstances where we would allow such a connection for brownfield sites only, however this will require significant justification from the customer taking account of various factors including legal, physical, and technical challenges.

In order to avoid costs and delays where a surface water discharge to our combined sewer system is anticipated, the developer should contact Scottish Water at the earliest opportunity with strong evidence to support the intended drainage plan prior to making a connection request. We will assess this evidence in a robust manner and provide a decision that reflects the best option from environmental and customer perspectives.

General notes:

- ▶ Scottish Water asset plans can be obtained from our appointed asset plan providers:
 - ▶ Site Investigation Services (UK) Ltd
 - ▶ Tel: 0333 123 1223
 - ▶ Email: sw@sisplan.co.uk
 - ▶ www.sisplan.co.uk
- ▶ Scottish Water's current minimum level of service for water pressure is 1.0 bar or 10m head at the customer's boundary internal outlet. Any property which cannot be adequately serviced from the available pressure may require private pumping arrangements to be installed, subject to compliance with Water Byelaws. If the developer wishes to enquire about Scottish Water's procedure for checking the water pressure in the area, then they should write to the Customer Connections department at the above address.
- ▶ If the connection to the public sewer and/or water main requires to be laid through land out-with public ownership, the developer must provide evidence of formal approval from the affected landowner(s) by way of a deed of servitude.
- ▶ Scottish Water may only vest new water or waste water infrastructure which is to be laid through land out with public ownership where a Deed of Servitude has been obtained in our favour by the developer.
- ▶ The developer should also be aware that Scottish Water requires land title to the area of land where a pumping station and/or SUDS proposed to vest in Scottish Water is constructed.

- ▶ Please find information on how to submit application to Scottish Water at [our Customer Portal](#).
-

Next Steps:

▶ All Proposed Developments

All proposed developments require to submit a Pre-Development Enquiry (PDE) Form to be submitted directly to Scottish Water via [our Customer Portal](#) prior to any formal Technical Application being submitted. This will allow us to fully appraise the proposals.

Where it is confirmed through the PDE process that mitigation works are necessary to support a development, the cost of these works is to be met by the developer, which Scottish Water can contribute towards through Reasonable Cost Contribution regulations.

▶ Non Domestic/Commercial Property:

Since the introduction of the Water Services (Scotland) Act 2005 in April 2008 the water industry in Scotland has opened to market competition for non-domestic customers. All Non-domestic Household customers now require a Licensed Provider to act on their behalf for new water and waste water connections. Further details can be obtained at www.scotlandontap.gov.uk

▶ Trade Effluent Discharge from Non Dom Property:

- ▶ Certain discharges from non-domestic premises may constitute a trade effluent in terms of the Sewerage (Scotland) Act 1968. Trade effluent arises from activities including; manufacturing, production and engineering; vehicle, plant and equipment washing, waste and leachate management. It covers both large and small premises, including activities such as car washing and launderettes. Activities not covered include hotels, caravan sites or restaurants.
- ▶ If you are in any doubt as to whether the discharge from your premises is likely to be trade effluent, please contact us on 0800 778 0778 or email TEQ@scottishwater.co.uk using the subject "Is this Trade Effluent?". Discharges that are deemed to be trade effluent need to apply separately for permission to discharge to the sewerage system. The forms and application guidance notes can be found [here](#).
- ▶ Trade effluent must never be discharged into surface water drainage systems as these are solely for draining rainfall run off.
- ▶ For food services establishments, Scottish Water recommends a suitably sized grease trap is fitted within the food preparation areas, so the development complies with Standard 3.7 a) of the Building Standards Technical Handbook and for best management and housekeeping practices to be followed which

prevent food waste, fat oil and grease from being disposed into sinks and drains.

- ▶ The Waste (Scotland) Regulations which require all non-rural food businesses, producing more than 50kg of food waste per week, to segregate that waste for separate collection. The regulations also ban the use of food waste disposal units that dispose of food waste to the public sewer. Further information can be found at www.resourceefficientscotland.com

I trust the above is acceptable however if you require any further information regarding this matter please contact me on **0800 389 0379** or via the e-mail address below or at planningconsultations@scottishwater.co.uk.

Yours sincerely,

Pamela Strachan

Development Services Analyst

Tel: 0800 389 0379

planningconsultations@scottishwater.co.uk

Scottish Water Disclaimer:

"It is important to note that the information on any such plan provided on Scottish Water's infrastructure, is for indicative purposes only and its accuracy cannot be relied upon. When the exact location and the nature of the infrastructure on the plan is a material requirement then you should undertake an appropriate site investigation to confirm its actual position in the ground and to determine if it is suitable for its intended purpose. By using the plan you agree that Scottish Water will not be liable for any loss, damage or costs caused by relying upon it or from carrying out any such site investigation."

REPORT OF HANDLING

| | | | |
|--------------------------------------|--|-------------------------|-------------|
| Ref No: | 21/01664/PPP | Officer: | Fiona Olsen |
| Proposal Description/ Address | Erect dwellinghouse on Site At Stratton Wood Fochabers Moray | | |
| Date: | 29.03.2022 | Typist Initials: | LMC |

| RECOMMENDATION | | |
|---|--------------------------|----------|
| Approve, without or with condition(s) listed below | | N |
| Refuse, subject to reason(s) listed below | | Y |
| Legal Agreement required e.g. S,75 | | N |
| Notification to Scottish Ministers/Historic Scotland | | N |
| Hearing requirements | Departure | N |
| | Pre-determination | N |

| CONSULTATIONS | | |
|------------------------------------|----------------------|--|
| Consultee | Date Returned | Summary of Response |
| Environmental Health Manager | 03/11/21 | No Objections |
| Contaminated Land | 11/11/21 | No Objections |
| Transportation Manager | 18/11/21 | No Objections subject to conditions and informatives |
| Scottish Water | 03/11/21 | No Objections |
| Strategic Planning And Development | 02/03/22 | <p>The proposal for a private residential house does not meet the criteria of policy EP7 as being an acceptable use to justify the removal of woodland and is contrary to policy. The application would result in the unacceptable change of use and permanent loss of land identified as woodland under the National Forestry Inventory Scotland.</p> <p>The proposal must also comply with the siting and design criteria set out within DP4. The siting of the proposed house has been deemed to be unacceptable as it would result in the permanent loss of woodland which is contrary to Policy EP7. Regardless of the number of trees that may or not be felled as part of the proposal, in land use terms the whole site is identified as woodland and there is strong policy support at a national and local level for it to be retained. In failing to comply with policy EP7, the proposal also fails to comply with the siting criteria of DP4.</p> |

| | | |
|--------------------------------------|----------|----------------------|
| Moray Flood Risk Management | 04/11/21 | No Objections |
| Planning And Development Obligations | 08/11/21 | Contributions Sought |

| DEVELOPMENT PLAN POLICY | | |
|---------------------------------------|------------|--|
| Policies | Dep | Any Comments (or refer to Observations below) |
| DP1 Development Principles | | See below |
| DP4 Rural Housing | | See below |
| EP7 Forestry Woodland and Trees | | See below |
| EP12 Management and Enhancement Water | N | Complies |
| EP13 Foul Drainage | N | Complies |
| EP14 Pollution Contamination Hazards | N | Complies |

| REPRESENTATIONS | | |
|---|-----|--|
| Representations Received | YES | |
| Total number of representations received: ONE | | |
| Names/Addresses of parties submitting representations | | |
| Name and address details of parties submitting representations withheld in accordance with the General Data Protection Regulations. | | |
| Summary and Assessment of main issues raised by representations | | |
| <p>Issue: All wildlife, flora and fauna on each site must be protected</p> <p>Comments (PO): This is an application for planning permission in principle for a new house in an area designated as woodland. The proposal does not comply with planning policy as it would result in the permanent loss of woodland for housing and as such will be refused.</p> <p>In terms of protected species, a tree survey report has been submitted which outlines that none of the surveyed trees had bat roosting potential, when surveyed from ground level and that there are no active badger setts within 30m or close by the development site.</p> | | |
| <p>Issue: Fauna will be present on each site and must be protected the same as wildlife.</p> <p>Comments (PO): Again, the proposal does not comply with planning policy as it would result in the permanent loss of woodland for housing and as such will be refused.</p> | | |

OBSERVATIONS – ASSESSMENT OF PROPOSAL

Section 25 of the 1997 Act as amended requires applications to be determined in accordance with the development plan i.e. the adopted Moray Local Development Plan 2020 (MLDP) unless material considerations indicate otherwise. The main planning issues are considered below:

Proposal

The application seeks planning permission in principle to erect a new dwellinghouse and associated services.

Site

The site is clearing with in an existing parcel of woodland, designated under the National Forest Inventory 2018 as 'conifer'.

The site is bound by woodland (also designated as the same) to the east and west and of the site. An area of farmland lies to the north. Finally the site is bound by the public road to the south.

There is no planning history on the site.

Policy Assessment (MLDP 2020)

Siting (DP1, DP4, EP7)

Policy DP4 refers to new housing in the open countryside and outlines the siting criteria for sites within areas of intermediate pressure. Parts 1 and 2 of the siting criteria outlined under DP4 require that there must be existing landform, mature trees, established woodland or buildings to provide acceptable enclosure and backdrop to the new house. It also must not create ribbon development or contribute to a build-up of new housing in the countryside. Parts 3 and 4 require that clear felling woodland to create plots will not be permitted and that 15% of any plot must be landscaped with native tree species of at least 1.5metres in height.

Policy DP1 requires that the scale density and character of all development must be appropriate to the surrounding area.

Policy EP7 outlines that woodland development which involves permanent woodland removal will only be permitted where it would achieve significant and clearly defined additional public benefits (excluding housing). The Additional Planning Policy Guidance further clarifies this position and states that Moray Council does not include housing within the definition of public benefits, sustainable economic growth, or rural/community development. For the purposes of policy EP7, "woodland removal" is defined as the permanent removal of 0.1 hectares or more of woodland, for the purposes of conversion to another type of land use.

The existing mature woodland in the northern, eastern and western parts of the site would provide acceptable enclosure and backdrop for a new house. A consented house lies to the north-east of the site (20/00350/APP and 21/01031/APP refers), the former being granted under the Moray Local Development Plan 2015 and the latter being granted whilst the former consent was still live. The proposed plot, when taken with the consented nearby plot would not give rise to ribbon development nor be considered to contribution to a build-up of new housing in the countryside. However, whilst the proposal to erect a dwellinghouse on this site would meet the siting criteria of parts 1 and 2, part 3 would not be met.

Part 3 states that the clear felling of woodland to create house plots will not permitted. It is noted that trees have previously been removed on site, prior to the planning application being submitted. A tree survey has been undertaken and the tree survey report submitted outlines that out of a total of 71 trees surveyed on site, 9 would be removed in order to form the proposed house plot. However, regardless of the number of trees intended to be removed in order to erect the house and associated services, the whole site is identified as woodland. Woodland comprises not only trees but the ground vegetation and soils in which trees sit. The proposal to change the use of the woodland to a house plot would fail to comply with policy EP7 as it would result in the permanent loss of land identified as woodland under the National Forestry Inventory Scotland.

The proposal must also comply with the siting and design criteria set out within DP4. Regardless of the number of trees that may or not be felled as part of the proposal, in land use terms the whole site is identified as woodland and there is strong policy support at a national and local level for it to be retained. Therefore, in failing to comply with policy EP7, the proposal also fails to comply with the siting criteria of DP4.

The agent has stated that the tree removal is required "to allow for sufficient access to the proposed development and for service ducts to be routed from the public road to the house". While the applicant may have tried to reduce the number of trees being removed for an access into the site, this does not address or overcome the fundamental policy departures in terms of the siting and inappropriate change of use of land from woodland to residential. It should also be outlined that only where woodland removal would achieve 'significant and clearly defined additional public benefits (excluding housing)' would it be eligible for removal and compensatory planting. This change of use of the woodland to residential does not meet the criteria for woodland removal and therefore, compensatory planting would not be considered. The tree survey and additional justification provided by the applicant are also insufficient to overcome these significant policy issues in this instance and therefore the proposal would not comply with the siting requirements of policies DP1 and DP4 as it would result in the permanent loss of woodland which is unacceptable in terms of policy EP7.

Design and Materials (DP1, DP4)

This is an application for Planning Permission in Principle only and therefore should the application be approved, the design and materials of the proposed house would be matters specified in conditions, to be assessed as part of a further application. These conditions would need to ensure that the design requirements of policies DP1 and DP4 were met.

Amenity, Landscaping and Trees (DP1, DP4)

Policy DP1 requires that the scale, density and character of all development be appropriate to the surrounding area, be integrated into the surrounding landscape and not adversely impact upon neighbouring properties in terms of privacy, daylight or overbearing loss of amenity. Policy DP4 requires that 15% of new house plot must be landscaped with native tree species to assist the development to integrate sensitively.

If the application were to be approved, boundary treatments and landscaping would be matters controlled by condition.

Access & Parking (DP1)

Moray Council Transportation Section have been consulted and have raised no objections subject to a series of conditions and informatives to be added to any final consent and therefore proposal would be considered acceptable in terms of the access and parking requirements of policy DP1.

Drainage & Water Supply (DP1, EP12, EP13)

Details of a foul water treatment and soakaway are shown on the submitted plans. A Drainage Report has been submitted which describes the proposed drainage arrangements and testing undertaken to ensure the site can be adequately drained. Moray Flood Risk Management have been consulted on the application and have raised no objections, however further details would require to be provided upon receipt of a full planning application.

It is proposed to connect the dwellinghouse to the public water supply. Scottish Water have been consulted and have raised no objections.

Therefore the proposal would meet the drainage and water supply requirements of policy DP1, EP12 and EP13.

Should the application be approved the agreed drainage design would also require to be a matter controlled by condition.

Developer Obligations and Affordable Housing (PP3, DP2)

A Developer Obligation towards transport and healthcare is sought as part of the application. An affordable housing contribution is also sought. The applicant has confirmed willingness to pay both of these, should the application be approved.

Recommendation

The proposal for a new house on this site would not comply with the siting requirements of policies DP1 and DP4 and would result in the permanent loss of woodland which is unacceptable in terms of policy EP7 and refusal is recommended.

OTHER MATERIAL CONSIDERATIONS TAKEN INTO ACCOUNT

None

HISTORY

| Reference No. | Description | | |
|---------------|-------------|--|------------------|
| | | | |
| | Decision | | Date Of Decision |

ADVERT

| | | | |
|------------------|-------------------|----------------|--|
| Advert Fee paid? | Yes | | |
| Local Newspaper | Reason for Advert | Date of expiry | |
| Northern Scot | No Premises | 25/11/21 | |
| PINS | No Premises | 25/11/21 | |

DEVELOPER CONTRIBUTIONS (PGU)

| | |
|--------|-----|
| Status | N/A |
|--------|-----|

DOCUMENTS, ASSESSMENTS etc. *

* Includes Environmental Statement, Appropriate Assessment, Design Statement, Design and Access Statement, RIA, TA, NIA, FRA etc

| | | |
|---|--|--|
| Supporting information submitted with application? | YES | |
| Summary of main issues raised in each statement/assessment/report | | |
| Document Name: | Drainage Report (07/10/2021) | |
| Main Issues: | Outlines testing and calculations undertaken to confirm ground suitability for both surface and foul water soakaways. Foul water will be directed to a packaged treatment plant before being directed to a sub-surface soakaway. | |

S.75 AGREEMENT

| | | |
|--|--|----|
| Application subject to S.75 Agreement | | NO |
| Summary of terms of agreement: | | |
| Location where terms or summary of terms can be inspected: | | |

| DIRECTION(S) MADE BY SCOTTISH MINISTERS (under DMR2008 Regs) | | | |
|---|---|--|----|
| Section 30 | Relating to EIA | | NO |
| Section 31 | Requiring planning authority to provide information and restrict grant of planning permission | | NO |
| Section 32 | Requiring planning authority to consider the imposition of planning conditions | | NO |
| Summary of Direction(s) | | | |



**MORAY COUNCIL
TOWN AND COUNTRY PLANNING (SCOTLAND) ACT 1997,
as amended**

REFUSAL OF PLANNING PERMISSION

**[Fochabers Lhanbryde]
Planning Permission in Principle**

TO

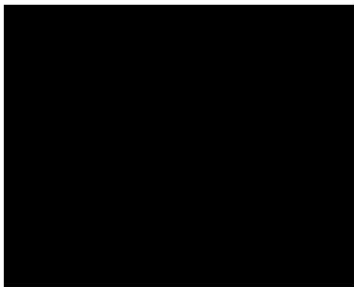

With reference to your application for planning permission in principle under the above mentioned Act, the Council in exercise of their powers under the said Act, have decided to **REFUSE** your application for the following development:-

Erect dwellinghouse on Site At Stratton Wood Fochabers Moray

and for the reason(s) set out in the attached schedule.

Date of Notice: **30 March 2022**

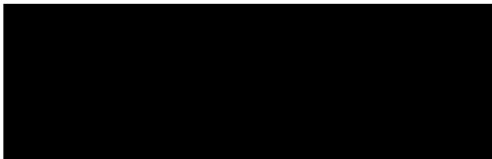

HEAD OF ECONOMIC GROWTH AND DEVELOPMENT
Economy, Environment and Finance
Moray Council
PO Box 6760
ELGIN
Moray
IV30 1BX

IMPORTANT
YOUR ATTENTION IS DRAWN TO THE REASONS and NOTES BELOW

SCHEDULE OF REASON(S) FOR REFUSAL

By this Notice, the Moray Council has REFUSED this proposal. The Councils reason(s) for this decision are as follows: -

The proposal for a new house on this site would not comply with the siting requirements of policies DP1 and DP4 and would result in the permanent loss of woodland which is unacceptable in terms of policy EP7 and refusal is recommended.

LIST OF PLANS AND DRAWINGS SHOWING THE DEVELOPMENT

The following plans and drawings form part of the decision:-

| Reference | Version | Title |
|------------------|----------------|--------------------------------|
| 2518-001 | | Location plan |
| 2518-020 | B | Site plan |
| SWF-2202-TP | | Tree protection and management |
| SWF-2202-AA | | Arboricultural assessment |

**DETAILS OF ANY VARIATION MADE TO ORIGINAL PROPOSAL,
AS AGREED WITH APPLICANT (S.32A of 1997 ACT)**

Revised site plan submitted to show proposed tree removal.

**NOTICE OF APPEAL
TOWN AND COUNTRY PLANNING (SCOTLAND) ACT 1997**

If the applicant is aggrieved by the decision to refuse permission for or approval required by a condition in respect of the proposed development, or to grant permission or approval subject to conditions, the applicant may require the planning authority to review the case under section 43A of the Town and Country Planning (Scotland) Act 1997 within three months from the date of this notice. The notice of review should be addressed to The Clerk, Moray Council Local Review Body, Legal and Committee Services, Council Offices, High Street, Elgin IV30 1BX. This form is also available and can be submitted online or downloaded from www.eplanning.scot/eplanningClient

If permission to develop land is refused or granted subject to conditions and the owner of the land claims that the land has become incapable of reasonably beneficial use in its existing state and cannot be rendered capable of reasonably beneficial use by the carrying out of any development which has been or would be permitted, the owner of the land may serve on the planning authority a purchase

notice requiring the purchase of the owner of the land's interest in the land in accordance with Part 5 of the Town and Country Planning (Scotland) Act 1997.

